

The World Leader in High Performance Signal Processing Solutions



Designing Programmable Logic Controller 4-20mA and Voltage I/O Modules: Techniques and Solutions.

Maurice Egan



The focus of this session concerns PLC Analog modules targeting industrial process control and industrial automation markets.

This is a big focus market for ADI and we offer solutions for the whole signal chain.

本次会议的重点是针对工业过程控制和工业自动化市场的PLC模拟模块。
这是ADI公司的一个很大的关键市场，我们为整个信号链提供解决方案。



AGENDA

- ◆ **Industrial Process Control**
 - **PLC**
 - ◆ Typical Module and Key Specs
 - ◆ Output Module Architectures
 - ◆ Input Module Architectures
 - ◆ **Field Transmitters**
 - **Loop Powered versus Non Loop Powered**
 - ◆ Application
 - ◆ Key Specs/Products
 - ◆ **PLC Reference Design**
 - Introduction

2



There are three sections to this presentation;

1. PLC analog output modules and PLC analog input modules,

Here I will detail the typical architectures and specifications for each and the associated products

2. The second section deals with Field Transmitters, the different types and the associated specs and products

3. Finally I will introduce our reference design for PLC analog output and analog input modules.

本次研讨会分为三部分：

1. PLC模拟输出模块和PLC模拟输入模块；

这一部分将详细介绍各个模块和相关产品的典型架构和规格。

2. 第二部分介绍现场数据发送器、不同的类型以及相关的指标和产品；

3. 最后将介绍PLC模拟输出和模拟输入模块的参考设计。

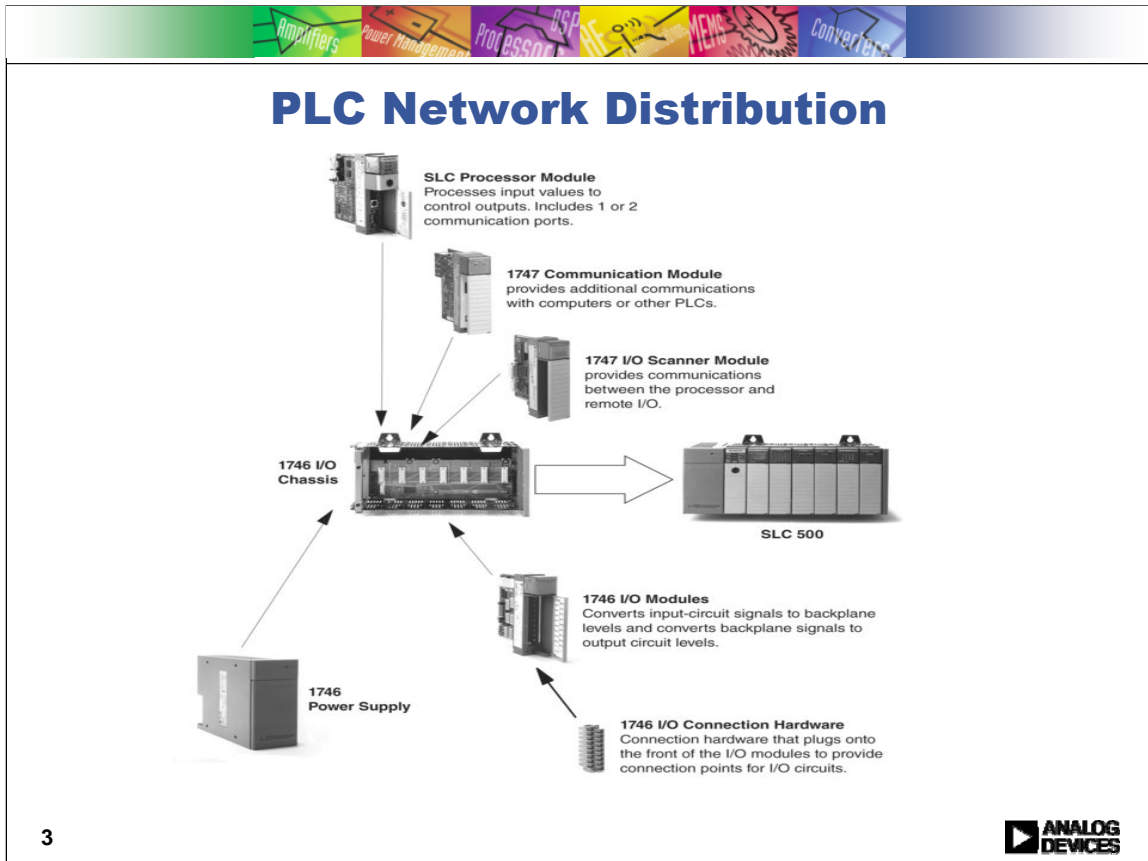

基本的PLC系统一般由四种不同类型的模块组成。

处理器模块负责系统的本地处理工作。在某些情况下，处理器也可以在I/O模块上。

通信模块处理本地处理器与远程处理器甚至其它PLC模块之间的通信。

通信协议可以是RS232、RS485或者其它类似的总线协议。

电源模块提供驱动系统中的其它模块所需的各种电压。用于模拟I/O模块的典型供电电压范围为18V至36V。

然后是I/O模块，可以是数字I/O模块或者模拟I/O模块。数字输出模块提供控制器与诸如电流接触器、继电器、BCD显示器和指示灯等外部输出器件之间的连接。

模拟模块采用适用于包括流量和压力的测量和控制在内的许多不同应用的各种输入和输出电压和电流（如4至20mA，+/-10V）。

The basic PLC system is generally made up of 4 different types of modules.

The processor module which handles the local processing for the system. In some cases there can also be processors located on the I/O modules.

The communications module handles communications between the local processor and remote processors or even other PLC modules.

	IC200ALG331	IC200ALG430	IC200ALG431	IC200ALG432	IC200ALG620	IC200ALG630
Product Name	VersaMax Analog Output Module, 14 Bit Voltage/Current 1500VAC Isolation, 8 Channel	VersaMax Analog Mixed Module, 12 Bit Input Current 4 Channel/Output Current 2 Channel	VersaMax Analog Mixed Module, 12 Bit 0-10V Input 4 Channel/Output 0-10V 2 Channel	VersaMax Analog Mixed Module, 12 Bit±10V Input 4 Channel/Output ±10V 2 Channel	VersaMax Analog Input Module, 16 Bit RTD, 4 Channel	VersaMax Analog Input Module, 16 Bit Thermocouple, 7 Channel
Input Range	N/A	4-20 mA	0-10 VDC	-10 to +10 VDC	RTD	Thermocouple
Output Range	± 10 VDC, 4-20 mA	4-20 mA	0-10 VDC	-10 to +10 VDC	N/A	N/A
Channel to Channel Isolation	N/A	N/A	N/A	N/A	Yes	Yes
External Power Supply	Range: 19.5-30 VDC including ripple; Current consumption: 100 mA maximum plus load currents	Range: 18-30 VDC including ripple; Current consumption: 125 mA maximum	Range: 18-30 VDC including ripple; Current consumption: 125 mA maximum	Range: 18-30 VDC including ripple; Current consumption: 125 mA maximum	None	None
Resolution		4 uA = 8 counts	2.5 mV = 8 counts	Input: 2.5 mV = 8 counts, Output: 5 mV = 16 counts		
Update Rate		0.3 ms maximum	0.3 ms maximum	0.3 ms maximum		

5



This is an example of the various ranges supported by one PLC family. One platform can support many different module configurations.

Each module has a different resolution, channel count and input/output configuration. For example, the first in the list is a 14 bit, 8-channel current and voltage output module. The second listed is a 12 bit module with 4 current input channels and 2 current output channels.

This allows the end user great flexibility in their module configurations.

One family of modules can have many different channel counts, from 2 channels up to 8 channels are shown for this family. Normally, this is configured in the factory and sold as separate module part numbers.

Input power supply ranges typically go from 18v-30v for PLC modules, the most common input value is 24v. Higher voltages can be required in current output transmitter modules, these are normally single channel designs.

这是一个PLC产品系列支持多个不同范围的范例。一个平台可以支持许多不同的模块配置。

每个模块都具有不同的分辨率、通道数和输入/输出配置。

例如，列表中的第一个模块是一个14位、八通道电流和电压输出模块。

列表中的第二个模块是一个具备4个电流输入通道和2个电流输出通道的12位模块。

这在模块配置时给最终用户带来了极大的灵活性。

一个系列的模块可能具有许多不同的通道数，这个系列的模块所具备的通道数从2个到最多8个。这一般是在工厂配置的，并且以独立的模块零件号销售。



Output Module - Key Specifications

Number of Outputs	4 voltage or current outputs
Module Location	1756 ControllLogix Chassis
Backplane Current	150mA @ 5.1V dc & 120mA @ 24V dc
Backplane Power	5.8W
Power Dissipation within Module	3.2W – 4 channel current
Thermal Dissipation	10.91 BTU/hr.
Output Range	+/- 10.4V 0 to 21mA
Resolution	15 bits across 10.4V - 320 μ V/bit – Voltage 15 bits across 21mA - 650nA/bit – Current
Data Format	Left justified, 2s complement – Integer mode IEEE 32 bit – Floating point mode
Open Circuit Detection	Current output only (Output must be set to >0.1mA)
Output Overvoltage Protection	24V dc
Output Short Circuit Protection	Electronically current limited to 21mA or less
Drive Capability	>2000 Ω – Voltage 0-750 Ω – Current
Output Settling Time	<2ms to 95% of final value with resistive loads
Calibrated Accuracy	Better than 0.05% of range from 4mA to 21mA, -10.4V to 10.4V
Calibration Interval	Twelve months
Output Offset Drift with Temperature	50 μ V/ $^{\circ}$ C 100nA/ $^{\circ}$ C
Gain Drift with Temperature	25 ppm/ $^{\circ}$ C – Voltage 520 μ V/ $^{\circ}$ C 50 ppm/ $^{\circ}$ C – Current 1.05 μ A/ $^{\circ}$ C
Module Error over Full Temperature Range ⁽¹⁾	0.15% of range – Voltage 0.3% of range – Current

- ◆ Resolution, up to 16 bits in present systems.
- ◆ Calibrated accuracy needs to be <0.05%
- ◆ Temperature Drift key spec, Offset, Gain and Total Output Drift

6



输出模块有三个重要指标：

分辨率、校准精度和温度漂移（也称为整个温度范围内的误差）

这里显示的是15位分辨率。如今的许多系统都需要16位分辨率。由于系统是闭环，因此16位分辨率通常并不是必需的，一般12位就可以了。分辨率决定最终系统的“微调能力”。如果在闭环系统中工作，那么系统可能不需要达到16位的分辨率，但是可能需要微调分辨率，该分辨率决定着对系统最终能够达到的固定设置点的接近程度。

这里的校准精度是在25° C下指定的。有时校准精度是在整个温度范围内指定的。

第三个重要指标是整个温度范围内的误差：

由于该指标包括线性误差、增益误差、偏置误差和输出漂移误差，因此这是一个重要指标。请记住，在60度的温度变化下产生10 ppm/ $^{\circ}$ C输出漂移的指标相当于给输出增加0.06%的误差。新型系统力求整个温度范围内的总误差低于0.1%。我们将其称之为系统的总不可调节误差（TUE）。

There are three key specifications for output modules;

Resolution, Calibrated accuracy and temperature drift also called error over full temperature range

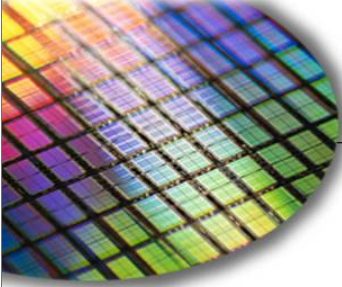

The World Leader in High Performance Signal Processing Solutions



Industrial Output Modules

Single Channel Architectures
Multi Channel Architectures



I'll now take a closer look at the output module

The output module transmits discrete or analog signals to activate various devices such as hydraulic actuators, solenoids or motor starters,

Signal conditioning, termination, and isolation are also part of the output module's functions.

The output module is treated in the same manner as the input module by the processor.

Output modules can be characterised as single or multichannel and we will see the architectural differences between both.

现在我将详细介绍输出模块。

输出模块发送离散信号或模拟信号来激活诸如液压起动机、螺线管或电动机起动机等各种设备。

信号调节、终止和隔离也是输出模块功能的一部分。

输出模块和输入模块通过同样的方法被处理器控制。

输出模块具备单通道或多通道的特性，我们将看到它们在架构上的区别。

Single Channel Architectures:

- ◆ **Discrete Solution.**
 - **Low Voltage 0-5V DAC, external amplifiers, resistors and FETS.**
 - ◆ Difficult to obtain temp performance with many discrete components.
 - ◆ Increased Board Size -> Increased Cost.
 - ◆ Open/Short Detection/Protection on outputs also difficult and increased board space.
- ◆ **DAC and Output Driver:**
 - **Low Voltage DAC, external driver.**
 - ◆ More Integrated solution.
 - ◆ Has open/short detection/protection.
- ◆ **Integrated Solution.**
 - **One Chip Solution.**
 - ◆ Low cost, small board size, integration of fault detection.

8



输出模块有三种主要的配置，传统设计采用带单电源DAC和外部放大器、电阻和FET的分立解决方案。这种架构会带来许多误差，特别是在整个温度范围内，这是因为在整个温度范围内采用热性能良好匹配的电阻比较困难并且成本较高。分立元件和诸如故障检测等附加功能增加了电路板空间，从而增加了设计成本。

新型系统则采用集成度较高的解决方案，比如采用独立的DAC和输出驱动器或者完全集成的单芯片解决方案。这些器件经过工厂校准和修正，误差已经消除，从而方便用户在无需校准的情况下使用。集成的电阻更容易与器件进行性能匹配并具有与器件一致的漂移特性，从而获得整个温度范围内更高的性能。

故障检测功能也可以方便地集成，这样可以减小电路板尺寸。

There are 3 main output configurations, older designs used a discrete solution with single supply DACs and external amplifiers, resistors, FETs. Many errors are introduced using this architecture, especially over temperature as it is difficult and expensive to use thermally matched resistors. Discrete components and adding features such as fault detection increase board space which adds cost to the design.

Newer systems use more integrated solutions, either a separate DAC and output driver or a totally integrated single chip solution. The Devices can be factory calibrated and trimmed and errors can be removed allowing end users in some cases needing no calibration. The integrated resistors are more easily matched and drift together leading to improved performance over temperature.

And fault detection can be easily integrated, allowing reductions in board size.

8

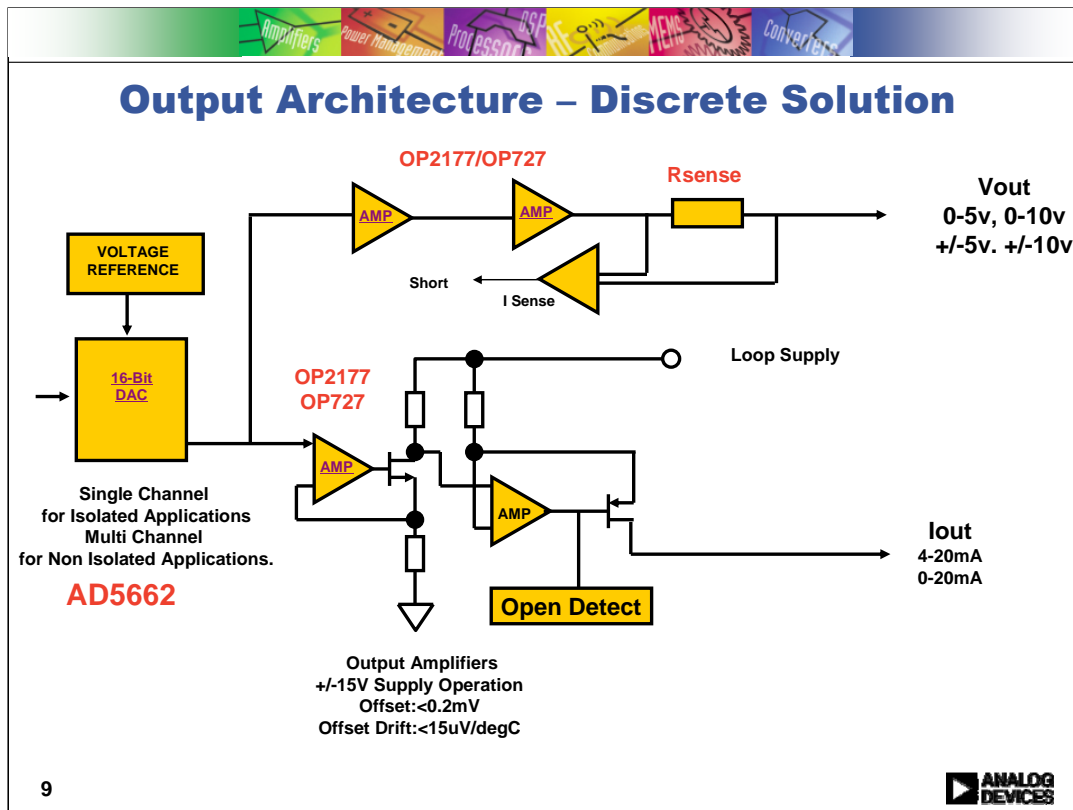

这是一个传统分立架构的例子。许多元件是必需的，如果需要故障检测功能，那么设计就会变得相当复杂。一些系统同时需要电流输出和电压输出，因此在设计同时具备这两种功能的大多数系统时，往往电路板存在大量冗余。如果要支持多种电压和电流输出范围，也会引起这个架构的诸多复杂问题。

Here is an example of an older discrete architecture. Many components are required and if fault detection is necessary then the design becomes quite complex. Some systems need both current and voltage outputs and therefore there is often a lot of board redundancy as many systems will be designed with both capabilities. Achieving the flexibility of supporting the many voltage and current output ranges would also pose complex issues for this architecture

AD5750 – Precision Analog Voltage/Current Output Driver

- ◆ **Features**
 - Software Prog PLC V/I Outputs
 - Use with Low-voltage nanoDAC™
 - Compact LFCSP packaging
- ◆ **IOUT Range:**
 - 4-20mA, 0-20mA, 0-24mA, ±20mA, ±24mA
 - 0.1% Accuracy (Total error)
 - 5ppm/C Output Drift
- ◆ **VOUT Range:**
 - 0-5V, 0-10V, ±5V, ±10V
 - 20% Overrange.
 - 0.05% Accuracy (Total error)
- ◆ **Functionality**
 - SPI Interface
 - Diagnostics/Fault detection
 - Digital input redundancy checker
 - Compliance
 - ◆ 12-V to 48-V supply, or dual ±12 V to ±24 V
- ◆ **Applications**
 - PLCs
 - Data-Acquisition
 - Distributed Control Networks

Generics	Packages
<ul style="list-style-type: none"> ◆ AD5751 – 60V compliance Unipolar V/I Outputs 	32-LFCSP

ANALOG DEVICES

我们可以采用AD5750来改进前面的分立设计。除了DAC之外，AD5750将上一张幻灯片中显示的所有分立电路都集成到一个单芯片中，同时增加了输出范围的软件可编程能力和故障检测功能。

这是一个专为工业应用设计的“纯模拟”输出驱动器芯片。该芯片接受一个模拟输入（0至4.096V）以及范围如幻灯片所示的电压输出或者电流输出，并且是一个软硬件可编程器件。这样，用户只需通过将外部引脚连接到高电平或低电平即可选择一个范围。另外，该器件可以通过SPI接口进行编程，从而允许用户在需要时对所有输出范围进行编程和更改。

AD5750具备以下几个重要特性：

电压和电流输出可以连到一起固定到一个输出终端，这样就可以减少模块所需的外部固定螺栓数量，从而降低成本。

该器件具备故障警报功能，该功能会指示内部寄存器和外部引脚是否发生了故障，可能发出警报的故障包括：

电压输出上的短路、电流输出开路、芯片温度过高，如果芯片温度超过150° C左右会触发警报，如果SPI接口上出现通信错误也会发出警报。

AD5750可以用48V的电源供电，这对于驱动较大负载电阻的应用非常有用。

We can greatly improve on the discrete design by using the AD5750. Excluding the DAC, The AD5750 integrates all of the discrete circuitry that was shown on the previous slide into a

one chip solution as well as adding software programmability of output ranges and fault detection features.

AD5750 – Software Mode

The diagram illustrates a typical system configuration for the AD5750 in software mode. An MCU is connected to the AD5750 via an SPI interface (SCLK, SDI, SDO, SYNC1) and a serial interface (SYNC2). The AD5750 is powered by VDD, AGND, and VSS. A voltage reference (REFIN) is provided by an ADR434, which also serves as the DAC supply. The DAC output (0-4.096V) is connected to the AD5750's VIN pin. The AD5750's VSENSE+ and VSENSE- pins are connected to the VOUT output, which can be configured for 0-5V, 0-10V, +/-5V, or +/-10V. The IOUT output can be configured for 0-20ma, 0-24ma, 4-20ma, +/-20ma, or +/-24ma. The AD5750 also includes a STATUS REGISTER for monitoring faults such as VOUT SHORT FAULT, IOUT OPEN FAULT, OVERTEMP FAULT, and RANGE ERROR. A HW SELECT pin is used to select between software and hardware modes.

◆ **Typical System configuration. AD5750 configured in software mode. DAC output 0-4.096v (e.g. AD5662) Reference (in this case ADR434) can be used for both DAC supply and Reference.**

11 ANALOG DEVICES

如上所述，AD5750可以以硬件方式和通过SPI接口进行配置。这里显示的是MCU通过SPI接口来控制AD5750。串行接口设置范围并读出器件状态。在硬件模式下，用户只需设置不同引脚的状态即可选择输出范围。

这个电路图还示出了AD5750如何与一个DAC和电压基准配合工作来完成电压和电流输出解决方案。

As previously mentioned the AD5750 is both hardware configurable and software configurable over an SPI interface, Shown here is the AD5750 connected to an SPI interface. The Serial interface sets the ranges and can read back the status of the device. In hardware mode the user simply sets the states of various pins to select the output range.

This diagram also demonstrates how with a DAC and voltage reference the AD5750 completes a voltage and current output solution.

AD5422 – 16 Bit, 4-20mA , $\pm 10V$

◆ Features

- 16-Bit Resolution and Monotonicity

◆ IOUT Range:

- 4mA-20mA, 0mA-20mA or 0mA-24mA
- 0.1% Accuracy
- 5ppm/C Output Drift

◆ VOUT Range:

- 0-5V, 0-10V, $\pm 5V$, $\pm 10V$
- Specified 0.05% Accuracy
- 3ppm/C Output Drift

◆ Functionality

- Reference (10 ppm/C)
- Compliance to 60 V
- Open and Short Detection.

◆ Applications

- PLC/DCS

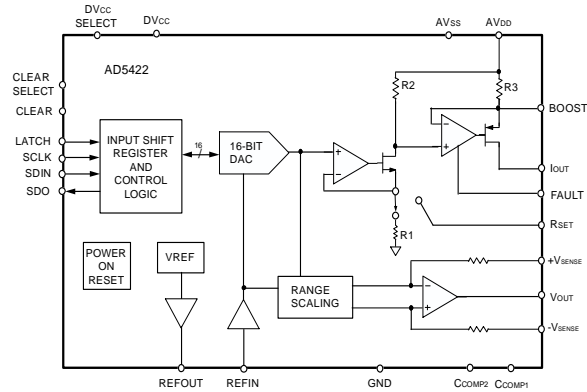

Generics

- ◆ AD5412- 12Bit $\pm 10V$, 4-20mA

Packages

- 24-TSSOP
- 40-LFCSP

12



我们可以通过集成一个16位DAC来对这个设计进行进一步的改进。

AD5422将一个输出驱动器、一个DAC和一个电压基准集成到一个芯片中，从而为电压和电流输出模块提供单芯片解决方案。如幻灯片所示，输出范围可以针对电流或电压进行编程。将整个电路集成到单个芯片，既改善了精度和温度漂移，又减小了电路板空间并降低了成本。

We can make further improvements to this design by integrating a 16-bit DAC, The AD5422 integrates an output driver , a DAC and a voltage reference into one chip providing a single chip solution for voltage and current output modules. The output ranges are programmable to either current or voltage as shown. The Integration onto one chip of the entire circuit offers improved accuracy, improved temperature drift, reduces board space and reduces cost.



Multi-Channel Architectures:

- ◆ **Discrete Solution.**
 - **Low Voltage 0-5V DAC, external switch, resistors and FETS.**
 - ◆ Bandwidth limitations due to switching:
 - ◆ Noise problems due to charge injection on switch changes
- ◆ **DAC and Output Driver:**
 - **Low Voltage DAC, external drivers.**
 - ◆ More Integrated solution.
 - ◆ Has open/short detection/protection.
- ◆ **Integrated Solution (Vout Mode).**
 - **One Chip 4 channel Solution.**
 - ◆ Low cost, small board size, integration of fault detection.
 - ◆ Programmable Output ranges.
 - ◆ Needs external circuitry for V to I conversion.

13



我们已经介绍了单通道架构和解决方案。关于多通道的设计，其解决方案与我们刚才介绍的单通道架构极其相似。

传统设计在分立解决方案中采用低压DAC（这里采用双通道DAC或四通道DAC）。

对于集成度更高的解决方案，有两种选择。一是采用带多个外部驱动器的低压多通道DAC，其好处在于外部元件最少。另一个选择是采用能够支持需要的所有电压范围（即0至5V、0至10V、+/-5V以及+/-10V）的多通道双极输出DAC，然后在需要时增加电压转电流电路。最终解决方案将取决于模块要求。

接下来会更加详细地介绍这些不同架构。

We've looked at single channel architectures and solutions. Another focus area is multi channel designs. The solutions are quite similar to the single channel architectures we have just seen.

Older designs use low voltage DACs (in this case duals or quads) for discrete solutions.

For more integrated solutions, there are 2 choices. One is to use a low voltage multi-channel DAC with multiple external drivers. The benefit here is that there is a minimum of external components. The other option is to use a multi-channel bipolar output DAC which can support all the voltage ranges that are required that is ;0-5v, 0-10v, +/-5v, +/-10v and then add the external voltage to current conversion circuitry as necessary. The end solution will depend on module requirements.

The next few slides outline these different architectures in a little more detail.

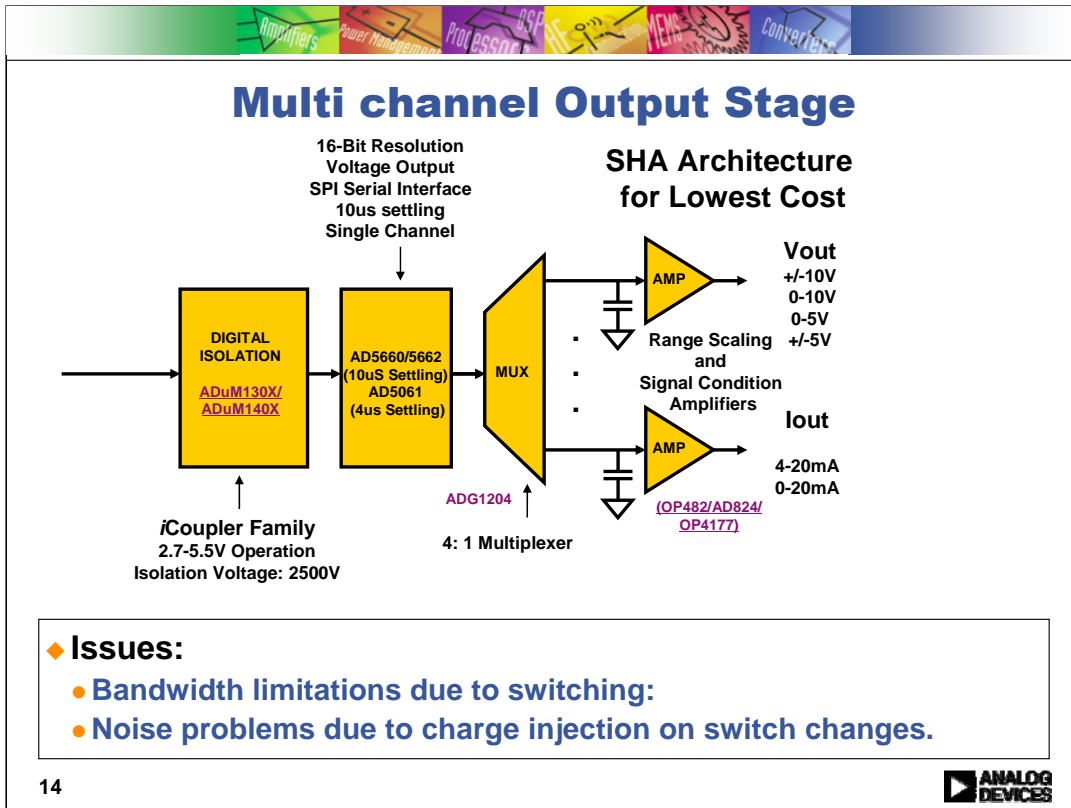

这是一个采用单个DAC以及外部多路复用器和放大器的低成本多通道解决方案，以创建取样和保持架构。随着通道数的增加，该解决方案会由于DAC刷新速率和稳定时间的原因而导致带宽出现问题。然而更为严重的是切换期间由于电荷注入转移而可能引起的短时脉冲波形干扰。这可能会给系统带来噪声和毛刺。这种配置适用于中低端设计。

This is a Low cost multi-channel solution using a single DAC and external multiplexer and amplifiers to create a sample and hold architecture. This will immediately have bandwidth limitations as the channel count increases due to the update rate and the settling time of the DAC. More critically however, is the glitching which may occur from the charge injection transfer during switching. This may add noise and glitches to the system. This configuration is most suited for mid to low end designs.

AD5066 DAC + AD5750 DRIVER + ADR434B REF

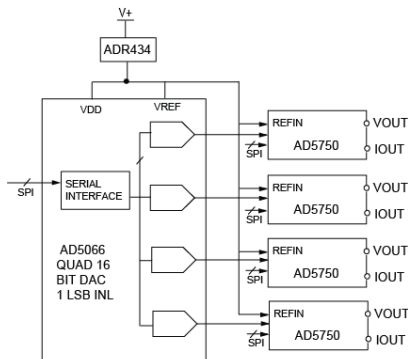

◆ System Errors

- **ADR434B**
 - ◆ 3 ppm/oC max
 - ◆ 0.04% Initial Accuracy.
- **AD5066**
 - ◆ Gain Error – 0.02%
 - ◆ Offset Error – 0.1mv.
- **AD5750**
 - ◆ TUE Error – 0.1%

◆ RESULT (0 to 60)

- **Total Un-Calibrated Error – .189%**
- **Total Drift Error (Offset/Gain etc removed) – 0.041%**
- **Board Area 88.64 mm².**
- **Will meet 0.3% with no Calibration in 0-60 Temp Range**

15



集成度更高的解决方案可以通过一个四通道低压DAC和四个输出驱动器来实现，无需其它外部元件。

采用这种架构可以在没有校准的情况下在60度得温度范围内实现0.3%的总误差。这些计算结果已经将DAC、驱动器和基准的最差漂移误差考虑在内。

如果系统经过校准消除了25° C下的偏置和增益误差，那么就可以把整个温度范围内的总误差限制到0.04%。

A more integrated solution can be configured with a Quad channel low voltage DAC and four output drivers. No other external components are needed. Using this architecture, one can achieve 0.3% total error across 60 degree temp range without calibration. These calculations take into account the worse case drift errors for the DAC, Driver and Reference and are therefore guaranteed.

If the system is calibrated to remove offset and gain error at 25° C then 0.04% total error can be achieved across temperature.

AD5066 – 5V, 16bit 1LSB Quad DAC

Low Voltage Single Supply Cores

KEY BENEFITS

- ◆ **Performance**
 - 16bit resolution, 1LSB INL
 - Low Gain Error Drift 1 ppm/oC
 - Offset Error Drift 0.5 uV/oC.
- ◆ **Flexibility**
 - Individual Ref to each DAC
 - LDAC pin – Allows asynchronous update
 - CLR pin – Can pre-program clear value
 - POR pin – Power on to mid or zero scale
 - SDO pin – Daisy chain multiple devices

A Member of the *nanoDAC* family

Resolution	Output	Channels	INL, Max	Interface	Package
16-Bits	0-5 V	4	1 LSB	SPI	14/16 TSSOP

Related Devices

- ◆ Same as AD5064 except
 - Quad 12/14/16bits – AD5024/AD5044/AD5064
 - Quad 16bit (Unbuffered) – AD5066
 - Dual 12/14/16bits - AD5025/AD5045/AD5065

16

AD5066是一个适合于这种高端设计的四通道16位DAC。它具备出色的增益误差、偏置误差和温度漂移指标，还具有高精度和高达16位的线性度。

该器件使得用户省去了系统校准工作，并提高了整个温度范围内的系统性能指标。

The AD5066 is a quad channel 16-bit DAC suitable for such high end designs. It offers excellent Gain Error, Offset Error and temperature drift specs as well as high Accuracy 16 bit linearity.

Using this part allows the end user to reduce system calibrations and increase system performance specs over temperature.

Amplifiers
Power Management
Processors
MEMS
Converters

AD5664 – World’s Smallest 16bit Quad DAC

Low Voltage Single Supply Cores

KEY BENEFITS

- ◆ **High Performance**
 - 16-Bit Resolution, 12LSB INL
 - 10 Pin MSOP / CSP
 -and also includes an on chip 5ppm/°C Reference
 - 70% Space saving over competition
 - ◆ Ideal for basestations, optical transceivers
- Reference and non reference options
- Dual Configuration also available



Industry’s Smallest
16-Bit Quad DAC

Also includes 5ppm on chip reference

16-pin SSOP/MSOP 70% smaller
10-pin CSP

A Member of the nanoDAC family

Resolution	Output	Channels	INL, Max	Interface	Package
16-Bits	0-5 V	4	12 LSB	SPI	10-LFCSP/MSOP

AD5644/24R	AD5663/43/23R	AD5664/24 & AD5663
◆ Same as AD5664R except <ul style="list-style-type: none"> ● 14/12-Bits Resolution 	◆ Same as AD5664 except <ul style="list-style-type: none"> ● 16/14/12 Bits ● Dual Configuration 	◆ Same as AD5664R except <ul style="list-style-type: none"> ● No on chip reference ● Quad and Dual configuration

17

在精度要求较低的应用中，可以采用16位四通道低压DAC---AD5664。该器件采用10引脚LFCSP封装，可以减小电路板尺寸。

该器件具备12位线性度，适用于大多数中高端模块。采用片上5 ppm/° C的基准，降低了总输出漂移。

AD5664是一个大产品系列中的一员，该产品系列可为电路设计工程师提供广泛的选择范围。

Where lower accuracy is required the AD5664 is a 16-bit quad channel low voltage DAC. It's 10 pin LFCSP package allows board size reduction.

It provides 12 bit linearity suitable for most mid to high end modules. Its on chip 5 ppm/° C reference reduces total output drift.

The AD5664 is a member of a large product family offering wide choice to the circuit designer.

AD5724/34/54R-Quad, Serial Input, 12/14/16-Bit DAC

KEY FEATURES

- ◆ Single/Dual Supply Operation
 - +4.5V to ±16.5V
- ◆ Programmable Output Range
 - +5V, +10V, +10.8V, ±5V, ±10V, ±10.8V
- ◆ Integrated Reference, 5ppm
- ◆ ±1 LSB INL @ 12 Bits
- ◆ 10µs Settling Time
- ◆ CLR to zero-/mid-scale
- ◆ 24-Lead TSSOP



Applications

- ◆ Industrial Automation
- ◆ Closed-loop Control
- ◆ Process Control
- ◆ PLC

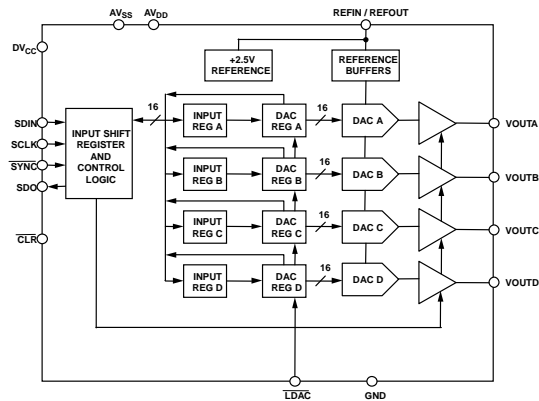

Temp	Final Release
-40° C – 85° C	Released
Sampling	
Now	
Related Devices	
◆ AD5722R/32R/52R Dual Channel	

18



适合于多通道应用的另一个产品是AD5754。该产品系列只具备电压输出，但是可以提供如幻灯片所示的一系列可编程输出范围，在电源选用方面，该系列具有极大的灵活性，可采用4.5V至16.5V的单电源或者双电源供电。低漂移集成基准降低了总系统漂移。整个产品系列提供带集成电压基准和不带集成电压基准的双通道和四通道12/14位以及16位转换器。

I want to introduce another product suitable for multichannel applications. The new AD5754 family of products are targeted at industrial applications. It is voltage out only but offers a range of programmable output ranges as shown, it is very flexible in its usable power supplies, operating from either a single or dual supply from 4.5V up to 16.5V. A Low drift integrated reference reduces total system drift. The entire family offers dual and quad channel 12/14 and 16 bit converters both with and without an integrated voltage reference.

AD5754 Configured as V to I

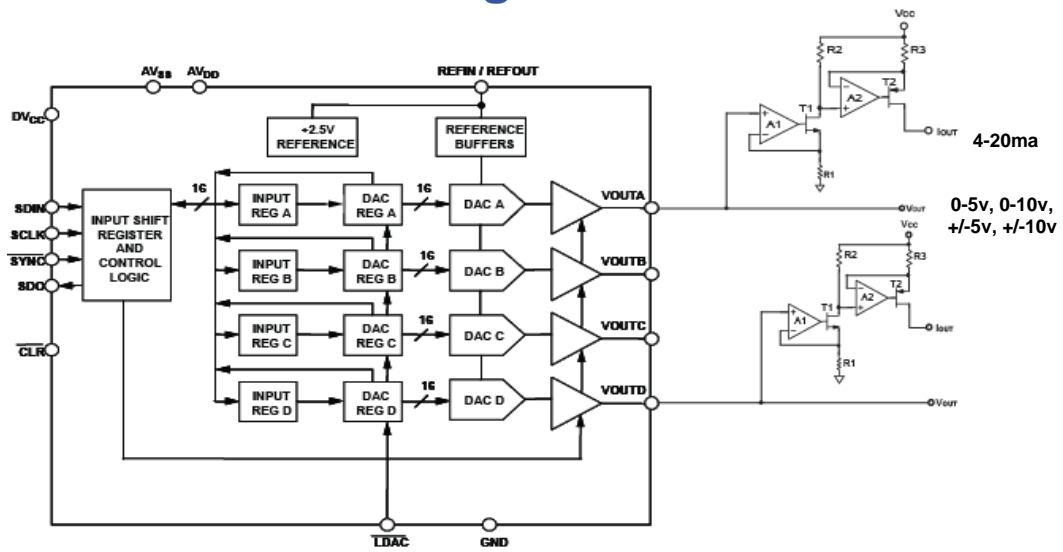

19



如果需要电流输出，可按幻灯片所示增加外部电路。
对于低端设计，可以选择12位器件与低成本放大器配合使用。

If a current output option is required external circuitry can be added as shown.
For low end designs the 12 bit part may be selected with low cost amplifiers.

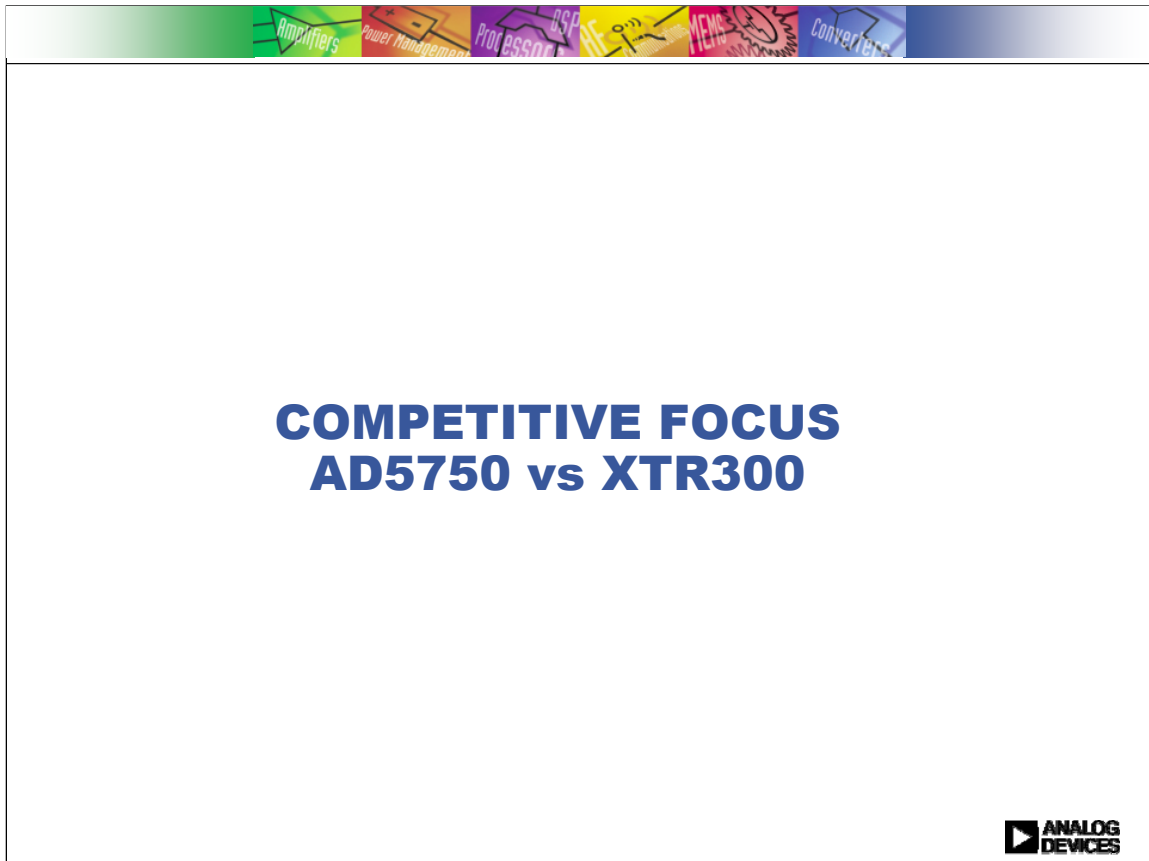

接下来的几张幻灯片将对AD5750及其主要竞争器件TI的 XTR300进行比较。

The next few slides give a comparison between the AD5750 and it's main competition, the XTR300 from TI

XTR300 – Range Configuration

Current Mode

The transconductance (gain) can be set by the resistor, R_{SET} , according to the equation:

$$I_{OUT} = \frac{10}{R_{SET}} V_{IN}$$

or when adding an offset V_{REF} to get bidirectional output with a single-ended input:

$$I_{OUT} = 10 \left(\frac{V_{IN}}{R_{SET}} + \frac{V_{IN} - V_{REF}}{R_{OS}} \right)$$

Voltage Mode

The IA gain can be set by two resistors, R_{GAIN} and R_{SET} :

$$V_{OUT} = \frac{R_{GAIN}}{2R_{SET}} V_{IN}$$

or when adding an offset, V_{REF} , to get bidirectional output with a single-ended input:

$$V_{OUT} = \frac{R_{GAIN}}{2} \left(\frac{V_{IN}}{R_{SET}} + \frac{V_{IN} - V_{REF}}{R_{OS}} \right)$$

- ◆ **3 external resistors R_{set} , R_{os} , R_{gain} set gain and polarity for 1 range only..**
- ◆ **Unless Switches+ further resistors 'or' a Potentiometer is used only one voltage and one current range can be configured ! Either would have issues for extra board layout and isolation.**

The transfer functions shown here demonstrate how the output range of the XTR300 is configured using external resistors, thus removing the possibility of easily reconfiguring for a different output range, Full programmability would require the addition of external switches or digital potentiometers. Compare this to how the AD5750 can be easily reconfigured over its SPI interface or by setting the Levels of a number of pins.

这里显示的传递函数说明了XTR300的输出范围是如何利用外部电阻进行配置的，这样就不再能够通过方便的重新配置来获得不同的输出范围。完全可编程能力将需要增加外部开关或数字电位器。而AD5750却可以方便地通过其SPI接口或者通过设置多个引脚的电平来重新配置。

AD5750 VS XTR300 FEATURES

Features	XTR300	AD5750
Package	30.25 mm ² (PQFP)	25 mm ² (LFCSP) ✓
Supply Range	+/-22v	+/-24v ✓
Temperature Range	-40oC to 85oC	-40oC to 105oC ✓
Output Ranges	Non Programmable	0-20ma, 4-20ma, 4-24ma, +/-20ma, +/-24ma ✓ 0-5v, 0-10v, +/-5v, +/-10v 2% Current Over Ranges 20% Voltage Over Ranges
Programmability	Need 3 external resistors to configure one range.	Software Programmable Ranges ✓
Fault Conditions	Open/Short/Over Temp (Fault Pin only – need isolators)	Open/Short/Over Temp Fault Pin or Bit ✓

22



From an overall point of view the AD5750 offers reduced package size, wider supply range, wider temperature range, is fully software programmable and has software readable fault conditions, which eliminates the need for costly isolators to read status pins.

总的来说，AD5750具备更小的封装尺寸、更宽的电源范围和更宽的温度范围，完全可通过软件进行编程，并且具备软件可读的故障状态，这样就不再需要高成本的隔离器来读出状态引脚了。

AD5750 VS XTR300 – V-mode Specifications:

Specification	XTR300	AD5750
Temp Range	-40 to 85	-40 to 85
Load Conditions	R Load = 1K ohm.	R Load = 2K ohm
Gain Error (25 max)	0.1%	0.005% (typ) ✓
Gain Error Drift	1 ppm/° C (0.006%) ✓	0.003%
Offset Error (25 max)	1.9mv (0.01%) ✓	0.015% (typ)
Offset Error Drift	6 uv/°C (.001875)	0.012% ✓
Linearity Error (typ)	0.01% FS	0.001% ✓
Linearity Error (max)	0.1% FS	0.02% ✓
TUE	$0.1+0.006\%+0.01\%+.001875+0.1 = 0.218\%$	< 0.1% max

23



Comparing the devices in Voltage output mode, the AD5750 specifies a better total accuracy and better drift performance, offering superior overall performance.

A good specification to compare is TUE, **the XTR300 offers 0.218%, whereas the AD5750 specifies 0.1%**, eliminating the need for calibration in a lot of cases.

通过对电压输出模式下的器件进行比较可见，AD5750具备更高的总精度和更好的漂移性能，因此具备更出色的总性能。

一个可以用来进行比较的好指标是TUE（总不可调节误差），XTR300的TUE为0.218%，而AD5750的最大TUE则小于0.1%，在许多情况下不再需要校准。

AD5750 VS XTR300 – I-mode Specifications:

Specification	XTR300	AD5750
Temp Range	-40 to 85	-40 to 105 ✓
Load Conditions	R Load = 800 ohm.	R Load = 300 ohm
Gain Error (25 max)	0.12%	0.01% (typ) ✓
Gain Error Drift	10 ppm/oC max	<10ppm max ✓
Offset Error (25 max)	1.8mv(0.094%)	0.0175% (typ) ✓
Offset Error Drift	6 uv/oc (.001875)	TBD
Linearity Error (typ)	0.01% FS	0.001% ✓
Linearity Error (max)	0.1% FS	0.02% ✓
TUE	$0.12+0.06\%+0.094\%+.001875+0.1$ = 0.376%	<0.1% max ✓

- ◆ Comment. For purposes of % FSR in current mode, range was considered to be 19.2v (24mA*800 ohm load). In voltage mode 10v range used for FSR.

24



In current output mode the situation is similar in that the AD5750 again offers superior overall performance, removing the requirement for system calibrations in a lot of cases.

电流输出模式下的情况与此类似，AD5750再次提供了优越的总性能，并且在许多情况下都不再需要系统校准。

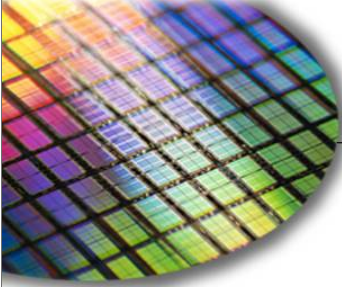

The World Leader in High Performance Signal Processing Solutions



Industrial Input Modules



That concludes the section on output modules.

Now focusing on the input module

The input module has two functions: reception of an external signal and status display of that input point. In other words, it receives the peripheral sensing unit's signal and provides signal conditioning, termination, isolation and/or indication for that signal's state.

输出模块部分的介绍到此结束。

现在介绍输入模块。

输入模块具备两个功能：外部信号的接收和该输入点的状态显示。换句话说，输入模块接收外设感应器件的信号，并进行信号调节、端接、隔离或该信号状态的指示。

Amplifiers
Power Management
Processors
DSP
MEMS
Converters

INPUT MODULE

Model	KV-AD4
Analog input range	Voltage: -10 to +10 V Current: 4 to 20 mA
Input impedance	Voltage: 1 M Ω Current: 300 Ω
Analog inputs	4 (4 channels)
Resolution	Input range ± 10 V 5 mV (1/4000) Input range 4 to 20 mA 4 μ A (1/4000)

Model	KV-DA4
Analog output range	Voltage: -10 to +10 V Current: 4 to 20 mA
Output impedance	0.5 Ω max. (when voltage output mode is selected)
Minimum load resistance	1 k Ω (when voltage output mode is selected)
Maximum load resistance	400 Ω (when current output mode is selected)
Analog outputs	4 (4 channels)
Resolution	Output range ± 10 V 5 mV (1/4000) Output range 4 to 20 mA 4 μ A (1/4000)

<div style="background-color: #0056b3; color: white; padding: 2px;">24 Bit Sigma Delta ADC</div> <ul style="list-style-type: none"> ◆ AD7792/3/4, AD7190 ◆ AD7734 Bipolar 	<div style="background-color: #0056b3; color: white; padding: 2px;">12-16 Bit ADC</div> <ul style="list-style-type: none"> ◆ AD7120 12 BIT, AD7688 16 BIT, ◆ AD7328 Multi Channel
--	--

KEY REQUIREMENT

- ◆ **INPUTS**
 - Communication or Sensors
 - ◆ Examples..
- ◆ **MULTI RANGE INPUTS**
 - Voltage 0-5, 0-10,+/-5V, +/-10V
 - Current 4-20ma
 - RTD, TC
- ◆ **Performance**
 - 12-16 Bit
 - ◆ Low/Mid End
 - 16-24 Bits
 - ◆ High End
 - ◆ Small Signal

26

与输出模块类似，输入模块可以针对各种不同的输入进行配置。输入模块往往具备比输出模块高的分辨率和精度。RTD和热电偶输入尤其需要较高的分辨率，这是因为它们的输入信号很小。对于电流输入，负载电阻一般在300至500欧姆左右。

这张幻灯片的底部显示的是本应用推荐使用的一些ADC。

Similar to the output module the input modules can be configured for a variety of different inputs. Typically the input modules tend to have higher resolution and accuracy than the output modules. RTD and Thermocouple inputs especially need higher resolution as they have small signal inputs. For a current input the load resistor normally tends to be in the region of 300-500 Ohms.

Shown at the bottom of the slide are some recommended ADCs for this application.

Amplifiers
Power Management
Processors
DSP
MEMS
Converters

INPUT MODULE KEY SPECS

Number of Inputs	16 single ended, 8 differential or 4 differential (high speed)
Module Location	1756 ControlLogix Chassis
Backplane Current	150mA @ 5.1V dc & 65mA @ 24V dc
Backplane Power	2.33W
Power Dissipation within Module	2.3W – Voltage 3.9W – Current
Thermal Dissipation	7.84 BTU/hr. – Voltage 13.30 BTU/hr. – Current
Input Range and Resolution	+/-10.25V – 320 μ V/count (15 bits plus sign bipolar) 0-10.25V – 160 μ V/count (16 bits) 0-5.125V – 80 μ V/count (16 bits) 0-20.5mA – 0.32 μ A/count (16 bits)
Common Mode Voltage Range	+/- 10.25V (20.5V between any two input terminals)
Data Format	Left justified, 2s complement – Integer mode IEEE 32 bit – Floating point mode
Input Impedance	>1meg Ω – Voltage 249 Ω – Current
Open Circuit Detection Time	Positive full scale reading within 5s – Differential Voltage Negative full scale reading within 5s – Single-ended/Differential Current Even numbered channels go to positive full scale reading within 5s, odd numbered channels go to negative full scale reading within 5s – Single-ended voltage
Overvoltage Protection	30V dc – Voltage 8V dc – Current
Normal Mode Noise Rejection ⁽¹⁾	>80dB at 50/60Hz
Common Mode Noise Rejection	>100dB at 50/60Hz
Calibrated Accuracy	Better than 0.05% of range – Voltage Better than 0.15% of range – Current
Calibration Interval	12 months
Input Offset Drift with Temperature	90 μ V/ $^{\circ}$ C
Gain Drift with Temperature	15 ppm/ $^{\circ}$ C – Voltage 307.5 μ V/ $^{\circ}$ C for +/-10.25V range; 153.8 μ V/ $^{\circ}$ C for 0-10.25V range; 76.9 μ V/ $^{\circ}$ C for 0-5.125V range 20 ppm/ $^{\circ}$ C – Current +/-0.41 μ A/ $^{\circ}$ C

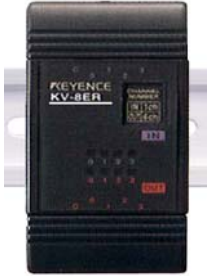

KV-8EX
8 input

KEY SPECS

- ◆ **Common Mode Rejection Ratio**
- ◆ **Calibrated accuracy to 0.05%**
- ◆ **Output Drift over Temp key Specs.**

27

A Key Specification in noisy industrial environments is Common Mode Rejection Ratio (CMRR) which is a measure of how successfully the inputs reject the common mode noise that has coupled onto the receive wires, especially for small signal inputs where noise can be gained up through a front end Programmable Gain Amplifier (PGA) stage. Accuracy at 25C and over temperature are also critical specifications.

在嘈杂的工业环境中，共模抑制比（CMRR）是一个重要指标，该指标是输入抑制耦合到接收电缆上的共模噪声的度量，特别是对于小信号输入，噪声可能通过前端可编程增益放大器（PGA）级被放大。25° C条件下的精度以及整个温度范围内的精度也是重要指标。

Requirements - AD7792/93/94/98/99

◆ Pressure Measurement (AD7798/99)

- Pressure Transducers, Weigh Scales, Strain Gauges
- Gain = 128; Fullscale i/p only 10mV
- High Precision – 22.5 ENOB (27nV rms noise)

◆ Temperature Measurement (AD7792/93)

- Thermocouple / RTD Sensors
- Programmable Current Sources for CJC and RTD biasing
- Gain = 32; Thermocouple fullscale i/p 20mV to 100mV typically
- High Precision – 22 ENOB (40nV rms noise)

◆ Flow Measurement (AD7794)

- Multi-Channel System
- Programmable Current Sources for Temperature Measurement
- High Precision – 22 ENOB (40nV rms noise)

28



There are a few different applications which have different system requirements.

这里有几个不同的应用，它们都具有不同的系统要求。

压力传感器、重量传感器和应变器的输出范围小，一般不超过10mV。因此在前端需要高增益PGA以及低噪声ADC。

对于温度测量，输入范围一般较大，高达40mV，因此这种高增益并不重要。但是对于像RTD这种类型的传感器，通常需要电流源。AD779x系列的Sigma-Delta转换器将所有这些都集成到一个芯片上。

流量计通常需要多个传感器，因此需要多通道输入。在这个案例中，AD7794集成了一个多路复用器，从而在一个器件上实现了多达6个可以进行测量的通道。

Pressure Transducers, Weigh-scales and Strain-gauges have small output ranges, typically only up to 10mv maximum. Therefore a high gain PGA is needed at the front end, along with a low noise ADC.

For Temperature measurement, the input range is normally larger, up to 40mv therefore such high gain is not as critical. But, for these type of

Transducers, like RTDs, current sources are generally required. The AD779x family of S-D convertes integrate all this onto one chip.

Amplifiers
Power Management
Processors
DSP
MEM
Converters

AD7190 – Product Description

4.8 kHz Ultra-Low Noise 24-Bit Σ - Δ ADC with PGA

- ◆ **7 nV rms Noise**
 - **21 bits noise free resolution**
◆ Gain = 128, Output Data Rate = 4.7 Hz
 - **23 bits noise free resolution**
◆ Gain = 1, Output Data Rate = 4.7 Hz
 - **16.5 bits noise free resolution**
◆ Gain = 128, Output Data Rate = 2.4 kHz
- ◆ **Output Data Rates 4.7 Hz to 4.8 kHz**
- ◆ **Selectable Gains 1 to 128**
- ◆ **Offset Drift 5 nV/° C**
- ◆ **Gain Drift 2 ppm/° C**
- ◆ **Specified Drift Over Time**
- ◆ **3.0 V to 5.25 V Power Supply**

24-Bit Σ - Δ ADC Delivers
Unmatched Speed and Precision

• 16-Bit Noise-Free Resolution (± 40 mV input @ 2.4kHz)

Resolution	Current	Channels	Output Data Rate	Interface	Package	Temperature
24-Bit	6 mA	2 / 4	4.7 Hz – 4.8 kHz	SPI	24-TSSOP	-40° C to +105° C

29

The AD7190 is a new part just recently sampling. It is an ultra low noise Sigma Delta ADC with an integrated PGA. It is the next generation to the AD779X family but with lower noise for even higher performance. With as low as 7nV of noise, 23 bits of noise free resolution can be achieved. This product is particularly targeting loadcell type applications where noise free performance is a key requirement.

AD7190是一个最新发布的新器件。该器件是一个带集成PGA的超低噪声 Σ - Δ ADC。它是AD779X系列的下一代产品，但是其噪声更低，并且具备更高的性能。噪声最低达7nV，可实现23位的无噪声分辨率。该产品特别针对称重传感器类应用，在这种应用中，无噪声分辨率性能是一个关键要求。

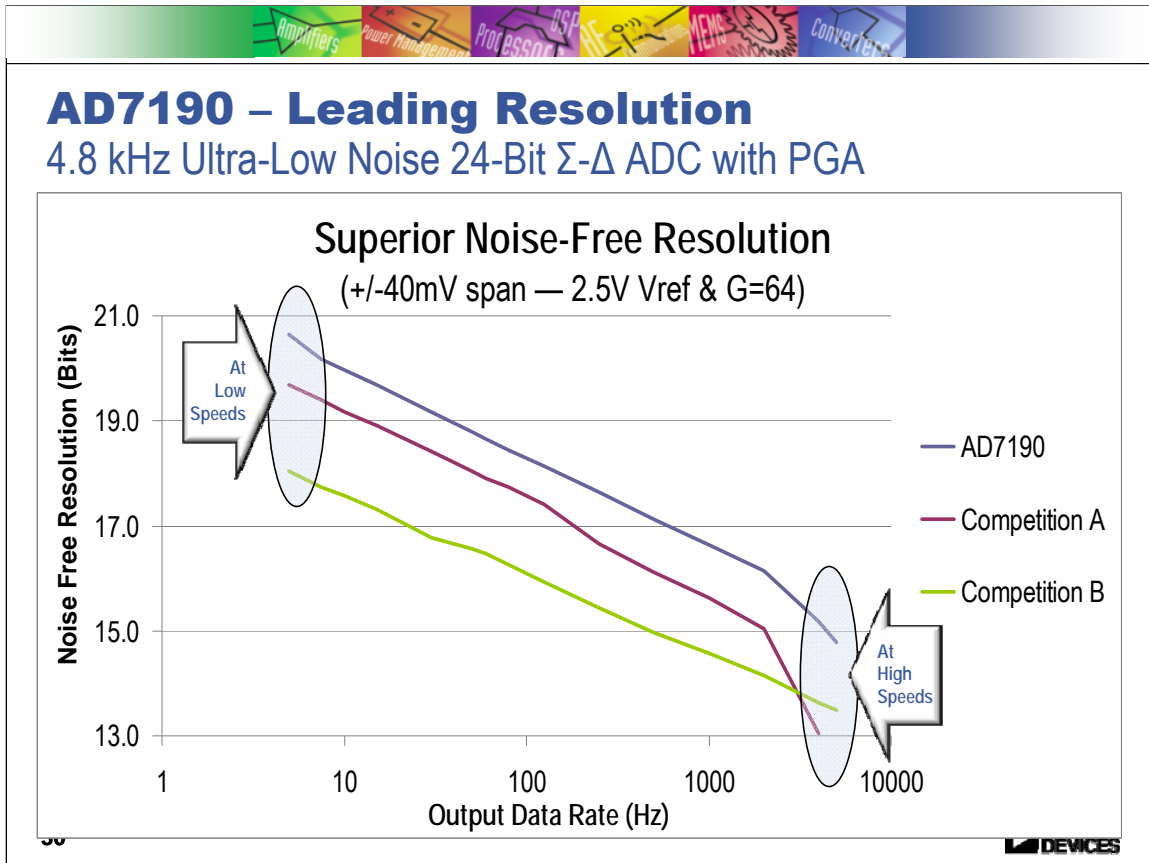

Noise free resolution is a key specification in many applications, this graph shows the lower noise performance

of the AD7190 versus competitors. The AD7190 has an added benefit over AD779X family in that it also has

higher update rates up to nearly 5Khz.

无噪声分辨率是许多应用的一个重要指标，这个曲线图显示，AD7190具备比竞争器件更好的噪声性能。相比AD779X产品系列，AD7190还拥有更多优点，AD7190具备将近5Khz的更高转换率。

AD7190 – Main Features

4.8 kHz Ultra-Low Noise 24-Bit Σ - Δ ADC with PGA

- ◆ Programmable Gain Amplifier, binary steps 1 to 128
- ◆ 2 Fully Differential Channels / 4 Pseudo-Differential Channels
- ◆ Selectable Chop or non-Chopped Input Signal
- ◆ Bridge Power Down Switch
- ◆ Temperature Sensor
- ◆ Diagnostics
 - Open Sensor Detect & Reference Detect
- ◆ Selectable Internal or External Clock
- ◆ Simultaneous 50 / 60 Hz Rejection @ 50 Hz o/p data rate
 - Also available at lower o/p data rates
- ◆ Selectable Zero-Latency Mode
- ◆ Selectable Sinc³ or Sinc⁴ Digital Filter
- ◆ SYNC pin to synchronise conversion on multiple devices
- ◆ 4 General Purpose Output Pins

31



The AD7190 is loaded with features. It includes all the features from the AD7799 family and more.

Such as;

An integrated PGA

Configurable input channels

Selectable chopping of input signal

Bridge Power down switch, for low power applications

Diagnostic features

50 and 60 Hz rejection

Selectable digital filters

General purpose output pins

AD7190具备诸多功能。它具备AD7799产品系列的所有功能以及其它更多功能，比如：

带有一个集成的PGA

具有可配置输入通道

具有输入信号的可选斩波功能

针对低功耗应用的桥式断电开关

带有诊断功能

50/60Hz抑制功能

可选数字滤波功能

AD7190 – Application Example

Weigh Scale Loadcell or Pressure Sensor Measurement

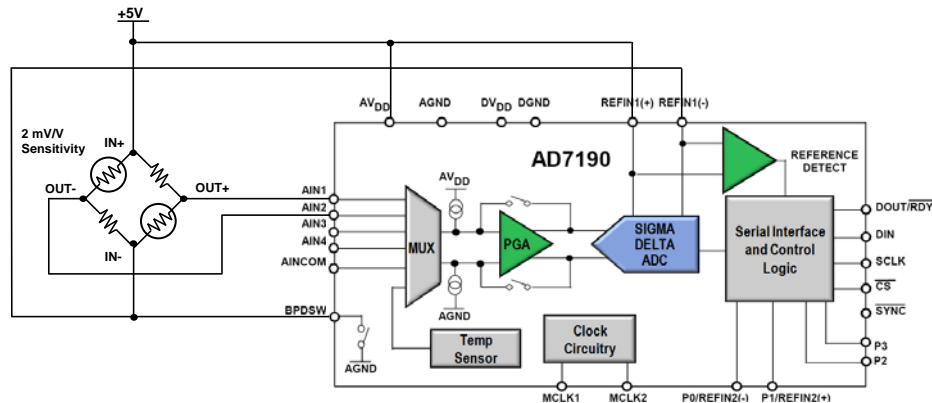

- **Exceptional precision for low speed & high speed Weigh Scale applications**
 - ◆ **7 nV rms noise (Gain = 128, 4.7 Hz Output Update Rate)**
 - ◆ **16.5 bits of noise free resolution (Gain =128, 2.4 kHz Output Update Rate)**
- **Lowest Offset Drift @ 5 nV/° C**
- **Power Save Mode via programmable Bridge Power Down Switch (BPDSW)**

32



这个电路图显示了针对AD7190的典型称重传感器连接。将电源连接至基准电压并且连接至称重传感器的激励电压意味着该设计的输出正比于电源电压。这使得电源中的所有噪声都能够自动消除，这是因为电源的变化还会影响电桥的基准电压和激励电压的变化。

内部时钟可以采用一个低噪声低漂移高精度外部时钟进行驱动。当需要精确的50/60Hz抑制时该功能特别有用。

This shows a typical loadcell connection for the AD7190. Connecting the Supply to the reference and to the excitation of the loadcell means the design is ratiometric. This allows any noise in the supply to be removed automatically as any change in supply will also effect a change in the reference and the excitation for the bridge.

The internal clock can be overdriven with a low noise low drift very accurate external clock. Specifically useful when accurate 50/60 Hz rejection is needed.

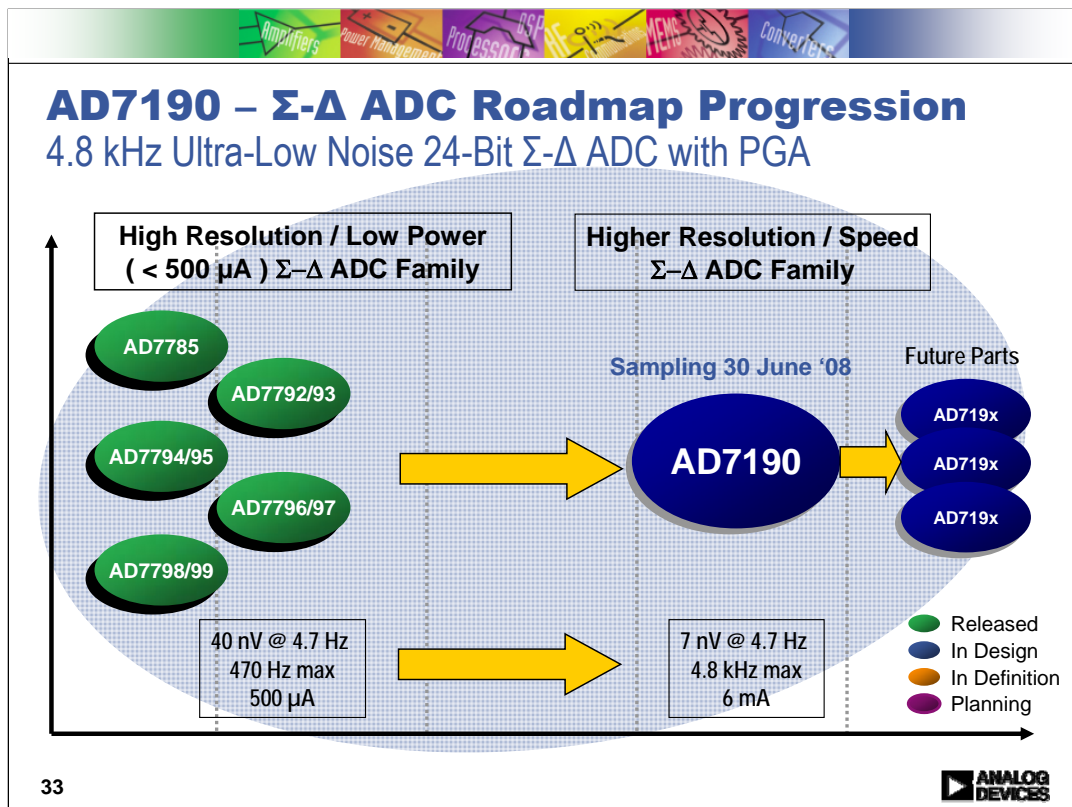

这张幻灯片显示了AD7190与AD779X系列产品的研发进程。AD779X系列产品定位于高性能低功耗应用。

AD7190系列产品定位于不十分注重功耗的超高端应用。因此AD7190以一定的功耗代价获得了更高的峰峰值分辨率。

This slide shows the AD7190s position versus the AD779X family. The AD779x family was targeted at high performance low power applications.

The AD7190 family is targeted at very high end applications where power is not as critical. So the AD7190 is trading off low power operation for improved noise free resolution

AD7190 – Roadmap*
4.8 kHz Ultra-Low Noise 24-Bit Σ - Δ ADC with PGA

PGA: Gain = 1 to 128 in binary steps

Model	Sample	Release	Noise	Channels	Package	Power
AD7190	30 Jun '08	31 Oct '08	7 nV	2/4	TSSOP-24	30 mW (5 V * 6 mA)
AD7192	11 Aug '08	31 Oct '08	10 nV	2/4	TSSOP-24	15 mW (5 V * 3 mA)
AD7194	31 Jan '09	30 Apr '09	10 nV	8/16	LFCS-32	15 mW (5 V * 3 mA)
AD7191	29 Sep '08	31 Jan '09	14 nV	2/4	TSSOP-24	15 mW (5 V * 3 mA)
AD7193	15 Sep '08	31 Jan '09	10 nV	4/8	TSSOP-28	15 mW (5 V * 3 mA)

*Sample & Release dates may be subject to change

ANALOG DEVICES

这些是AD7190系列产品提供的各种型号，它们的通道数和噪声性能不同。产品覆盖双通道器件到16个输入通道的器件AD7194。

样片和发布时间表也已经确定。整个产品系列计划在2009年发布。

These are the various models being offered from the AD7190 family, differentiated by channel count and noise. Offering from a 2-channel device up to 16 input channels with the AD7194. The sample and release schedules are also detailed. The entire family are scheduled for release in early 2009.



High Level Inputs

0-5v, 0-10v, +/-5v, +/-10v
4-20ma.



前面幻灯片介绍的是低电平输入应用及适用的产品，有的应用也要求输入模块具备转换高达 $\pm 10V$ 电压和 $20mA$ 电流输入的能力。

The previous slides dealt with low level inputs and the suitable products, there are also requirements in input modules to be able

To convert high level voltages of up to $\pm 10V$ and current inputs up to $20mA$

Input Module – Medium, High Level Inputs:

- ◆ **High Voltage/ High Current inputs are normally designed on separate modules to RTD/TC Modules:**
 - **4-20mA, 0-5V, 0-10V, +/-5V, +/-10V Input Module**
 - ◆ High Precision – Sigma Delta
 - ◆ High Speed Medium Precision – SAR.
 - **RTD/TC Module**
 - ◆ **Small Signal Inputs**
 - Needs Gain
 - Generally Sigma Delta ADC used.

36



输入模块被设计成能够接收宽范围的输入，从高压双极性输入到小信号RTD输入。根据需求的不同，可以采用不同的设计架构。我们将在接下来的幻灯片中讨论这些问题。

Input modules are designed to accept a wide variety of inputs from high voltage bipolar inputs to small signal RTD/TC inputs. Depending on requirements, different Design architectures may be used. We will discuss these in the following slides.

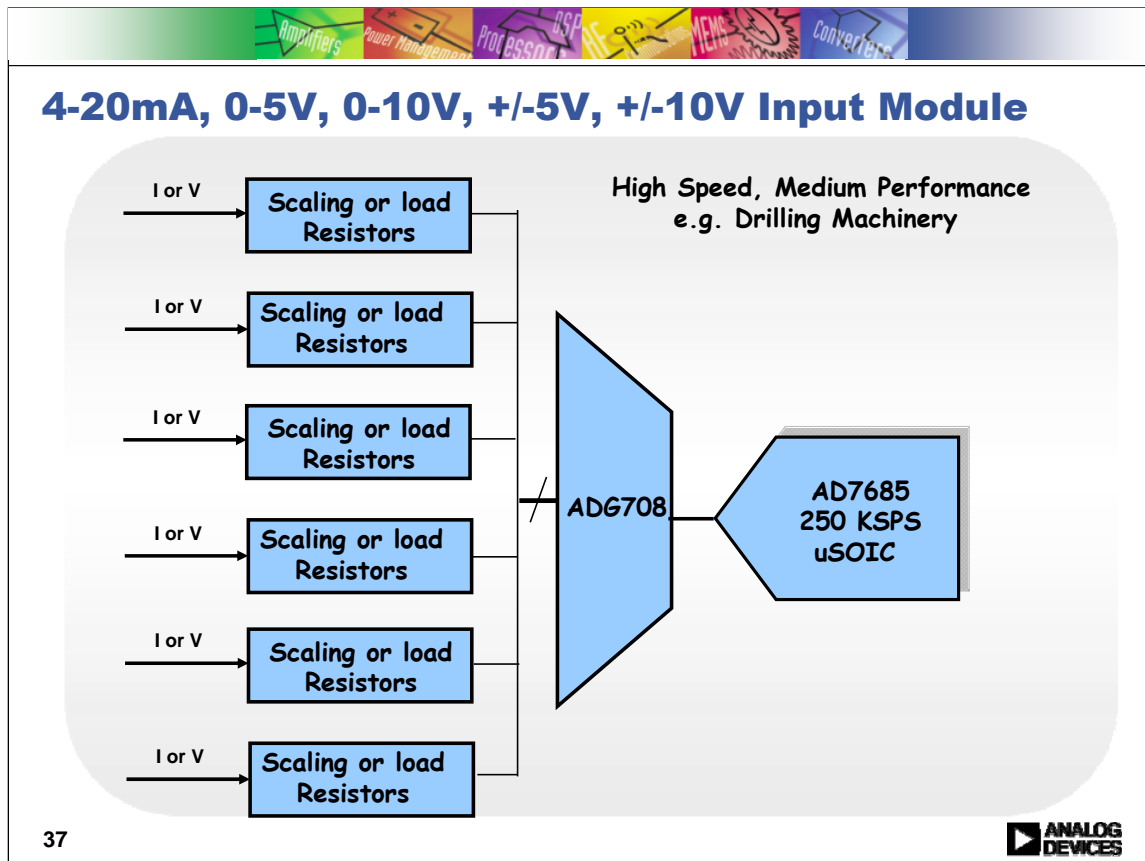

高电压或高电流输入可以采用单极或双极ADC来设计。如果按上图所示采用单极配置，那么就必须采用一个电阻网络，将信号调整到0至5V的范围内。这可能会引起性能上的折衷，比如电阻会给电路增加噪声。同时，由于电阻分压器的原因，还可能在信号链中引起增益损失。这里显示了AD768X系列器件，它们可以在高达几百KHz转换速率、5V输入电压范围的情况下提供16位分辨率。

High voltage or high current inputs can be designed with a uni-polar or bipolar ADC. If a uni-polar configuration is used as shown above, then

A scaling resistor network will have to be used to scale the signal to within the 0-5v range. This can have some tradeoffs, such as the resistors adding noise into the circuit. Also, there may be some gain loss in the signal chain due to the resistor divider. The AD768X family of parts is shown here. They offer 16 bit resolution at 5v at high conversion rates in the hundreds of Khz.

Amplifiers
Power Management
Processors
MEMS
Converters

AD7682/7689, AD7692/7699, AD7949 4-Channel and 8-Channel: 14- and 16-bit ADCs

KEY BENEFITS

- ◆ **High Performance**
 - Up to 500kSPS, 91dB SNR min
 - 2.7V (250kSPS) and 5.5V (500kSPS) operation
 - 16-bits NMC, 2LSBs INL Max
- ◆ **Features**
 - Pin-pin compatible with 14-bit and faster versions
 - Multiple input configurations (SE, pseudo-bipolar)
 - VREF buffer options: 2.5V, 3V, 4.096V

Resolution	Input	Channels	INL, Max	Interface	Package
To 16-bits	0-VREF, +/-VREF	4 & 8	2LSBs	SPI	QSOP-24

Four Channel AD7682 and AD7692	Eight Channel AD7689 and AD7699	Eight Channel AD7949
◆ AD7682 <ul style="list-style-type: none"> ● 16-bits, 250k, 2.7V ◆ AD7692 <ul style="list-style-type: none"> ● 16-bits, 500k, 5V 	◆ AD7689 <ul style="list-style-type: none"> ● 16-bits, 250k, 2.7V ◆ AD7699 <ul style="list-style-type: none"> ● 16-bits, 500k, 5V 	◆ 250kSPS, 2.7V operation

38

这里显示的AD768X/9x系列器件是14位和16位的转换器，它们都集成了片上多路复用器，提供4个或8个输入通道，这节省了用户的电路板空间，并提供了低成本的解决方案。输入通道可以配置成单端或伪差分输入。

The AD768X/9x family of parts shown here are 14 and 16 bit converters and they integrate a multiplexer onto the chip, offering 4 or 8 input channels, this saves the user board space and provides a lower cost solution. The input channels can be configured as single ended or pseudo differential

Amplifiers
Power Management
Processors
MEM
Converters

AD7328 – Software Selectable Multi-Ranging True Bipolar 12-bit plus Sign ADC

KEY BENEFITS

- ◆ **Software Selectable Input Ranges**
 - ◆ $\pm 2.5\text{ V}$, $\pm 5\text{ V}$, $\pm 10\text{ V}$ bipolar range
 - ◆ 0 V to 10 V unipolar range
 - ◆ Unipolar & Bipolar ranges are software selectable
 - ◆ Configurable as True Differential, Pseudo Differential & Single-Ended i/ps
- ◆ **High Input Impedance Eases Drive Requirements**
 - ◆ 125k Ω input impedance
- ◆ **Lowest Power Bipolar ADC**
 - ◆ 12mW @ 1MSPS

Resolution	Throughput	Channel No.	Interface	Power Supply	Package
12-Bit + Sign	1 MSPS	8	Serial	3V to 5V	20-lead TSSOP

AD7322, AD7324

- ◆ As per AD7328 except
 - ◆ 2 channels – AD7322
 - ◆ 4 channels – AD7324

AD7321, AD7323, AD7327

- ◆ As per AD7328 except
 - ◆ 500 kSPS
 - ◆ 2, 4, 8 channels

AD7328可以用于仅需12位分辨率的低端系统。其主要特性在于输入范围为双极性，并且范围可以通过软件进行编程，输入范围可以配置成单极性或双极性的2.5V至10V。

且其高输入阻抗特性使大多数系统不再需要外部驱动缓冲器。

The AD7328 can be used for lower end systems that only need 12 bits of resolution. The main feature here is that the input range is bipolar and

the ranges are programmable through software, the input range can be configured as unipolar or bipolar from 2.5V up to 10V.

A high impedance input eliminates the need for external drive buffers for most systems.



接下来我们将讨论用于工业控制系统的4至20mA电流环路发送器的结构。
包括发送器的两个主要类型、目标应用以及构成它们的元件。

The next section I will present discusses the structure of 4 to 20mA current loop transmitters used in industrial control systems,

Taking a look at the two main types of transmitter, where they are used and what components make them up.

Basic premise is to measure a process variable and transmit the result over a long distance to the control room

◆ **Process Variable**

- Temperature
- Pressure
- Fluid Flow
- Corrosion
- Flame/Gas Detection

◆ **Installed Sites**

- Oil/Gas Refinery
- Power Generation
- Steel Production
- Harsh industrial Environments

Sensor → Tx → 4 to 20mA Current → Rx (Control Room)

Up to 2 km

41 ANALOG DEVICES

发送器一般位于远离控制室的位置，用来测量控制如温度、压力、流量或类似的过程变量。

新型的发送器正在往智能化方向发展，在通过电流环路向控制室发送信号前，可以对测量结果进行线性化或取平均处理。

电流环路本身不会由于通过长电缆而发生信号衰减，并且不会受噪声影响，这就是它们被用于诸如发电站或炼油厂等恶劣的工业环境的原因。

发送器的输出信号范围可为4mA至20mA，分别代表零度和满度。

The transmitter is situated far from the control room measuring a process variable such as temperature , pressure , flow or similar process variable.

Modern transmitters tend to include intelligence for processing of the measurements (linearisation, averaging etc.) before transmitting it to the control room over the current loop.

A current loop is inherently immune to signal attenuation over long cables and the influence of noise, which is why they are used in harsh industrial

Environments such as power generation or oil refinery. The transmitter output signal is scaled from 4 mA, representing Zero-Scale value to 20 mA, representing Full-Scale value.

Two Categories of Transmitter

◆ Loop Powered

- Two wire connection supplying both power and communication
- Power is supplied over the current loop from the control room
- Entire transmitter must operate on $< 3.2\text{mA}$ for a standard transmitter and $< 2.7\text{mA}$ for a HART enabled transmitter
 - ◆ Low Power Consumption is critical for operation

◆ Non-Loop Powered (Locally Powered)

- Four wire connection, 2 for power and 2 for communication
- No power consumption limitations
- Used in situations where sufficient power cannot be derived from the current loop.

42



发送器有两种主要类型，分别是环路供电的发送器和本地供电的发送器。

环路供电的发送器仅有两线连接，通过电流环路汲取电源。

由于零标度值为 4mA ，所以这是发送器能够用来给自身供电的最大电流。

事实上，如果将环路上的故障警报电流和数字通信考虑在内的话，这个供电电流甚至会更小。

非环路供电的发送器有四线连接，其中两线用于电流环路，另外两线用于本地供电。这些发送器的功耗不受限制，一般用于所需电源比环路能够提供的电源高的情况下。

There are two main types of transmitter, loop powered and non-loop or locally powered transmitters.

Loop powered transmitters have only a two wire connection and so take their power supply from the current loop over which they are transmitting.

Because the zero-scale value is 4mA , this is the maximum amount of current the transmitter can take to power itself, in reality it is even less than this when

Fault alert currents and digital communications on the loop are taken into account.

Non-loop powered transmitters have a four wire connection, two connections for the current loop and two for a local supply, these transmitters are not power consumption limited

And are typically used in situations where more power than the loop can supply is required.

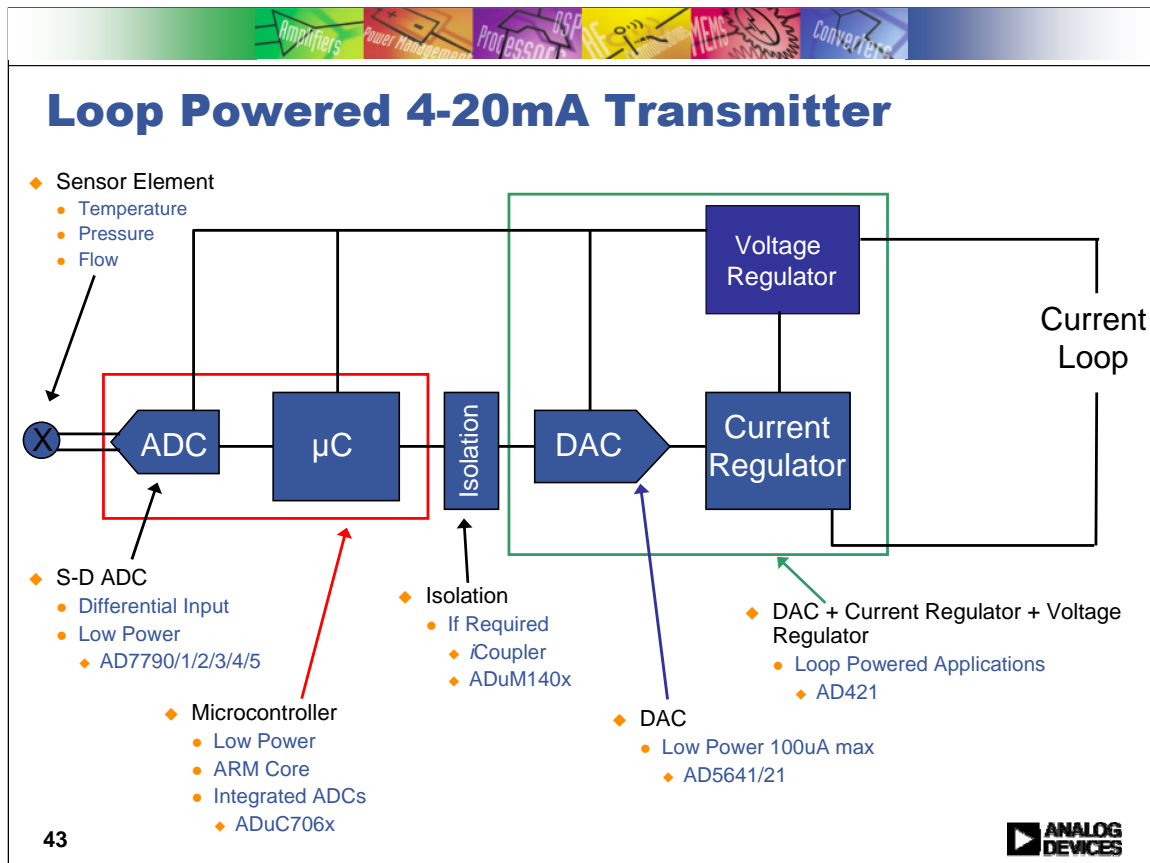

本页幻灯片给出了环路供电的发送器结构。

一个传感器元件被用来测量环境参数或过程变量，比如热电偶，RTD或电容传感器等。

一个模数转换器被用来转换传感器的测量结果，比如AD779x系列产品。

一个微控制器被用来处理测量结果并控制整个发送器，比如ADuC706x系列产品。

如果需要隔离，可将隔离器置于微控制器和数模转换器之间，比如ADuM140x系列产品。

微处理器控制数模转换器，而数模转换器控制环路电流，比如AD421。

AD421集成了一个数模转换器，环路电流驱动器和一个被用来控制整个发送器电源的稳压器。

Here is shown the structure of a loop powered transmitter

A sensing element such as a Thermocouple, RTD or Capacitive sensor measures an environmental parameter or process variable

An ADC converts the measurement , e.g. AD7790/91/92/93/94/95

A microcontroller is required to processes the measurements and control the entire transmitter e.g. ADuC706x

Isolation if required (20% of transmitters) is implemented between the microcontroller and the DAC. e.g. ADuM140x

The microcontroller controls the DAC which in turn controls the loop current e.g. AD421

The AD421 integrates a dac , current loop driver and a voltage regulator which regulates the power supply for the entire transmitter

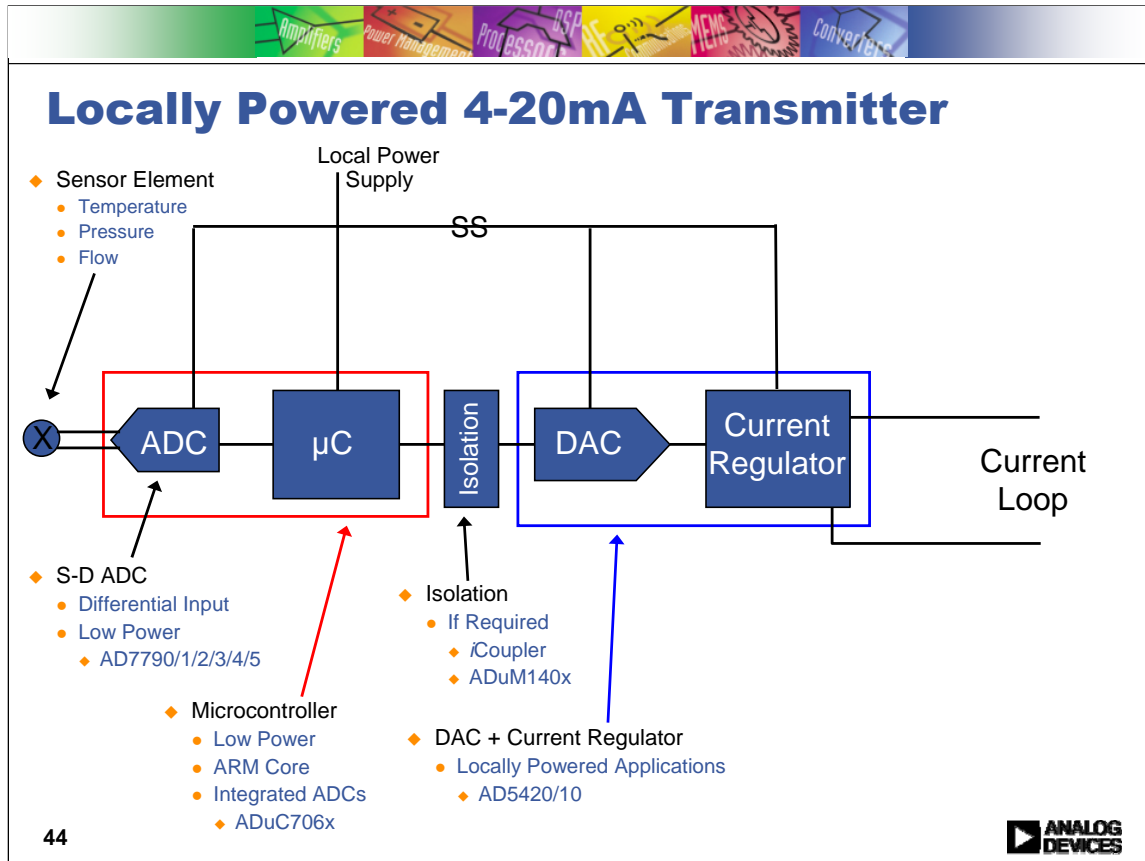

除了供电方式不同外，本地供电的发送器基本结构与环路供电的发送器类似。这里，发送器用本地电源，建议采用AD5420做环路驱动器，它集成了一个数模转换器和环路驱动器。

The basic structure of a locally powered transmitter is similar except for how it is powered

In this case the power source is local to the transmitter and a different product is recommended as the loop driver, the AD5420, which integrates a dac and loop driver.

Loop Powered Transmitter

◆ Total Power Budget is 3.2mA

- AD421 – 750 μ A max
- ADuC706x – 2.8mA max @ 1.28MHz (1.4mA from Loop)
- Total Consumption – 2.15mA
- 1.05 mA left for Sensor and other miscellaneous circuitry

◆ Further Power can be saved by running the ADuC706x Slower

- 1.6mA @ 80kHz

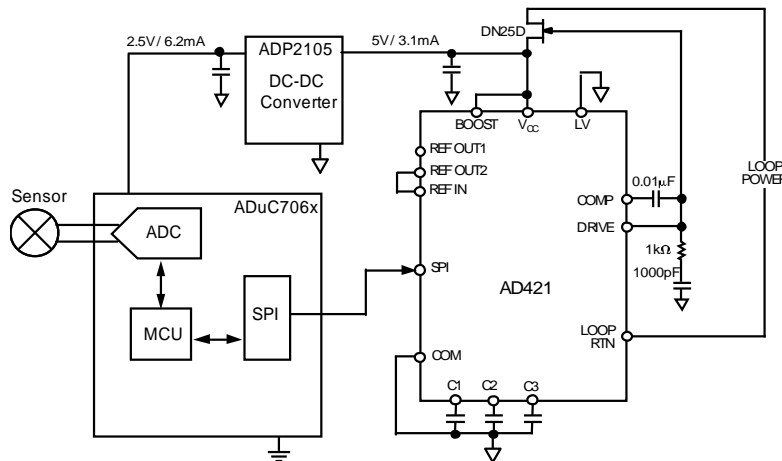

45



这里显示的是采用微控制器ADuC7060、4至20mA发送器芯片AD421以及稳压芯片ADP2105实现的回路供电的发送器的基本应用框图。

回路供电发送器的一个重要指标是功耗，整个发送器消耗来自回路的电流必须低于4mA。

AD421产生稳定的5V DC输出。ADP2105将此输出降压至2.5V以用于数字电路，从而使数字电路能够使用的电流提高到5V供电时的电流的两倍左右。

该器件采用5V电源供电。

发送器必须能够通过将回路电流设置为最小值3.2mA（最差情况）来提示故障状态。如果发送器还必须支持HART数字通信协议，此时 ± 0.5 mA FSK信号被调制到回路电流上，情况会更复杂。这里，发送器必须能够提示故障状态，并将 ± 0.5 mA信号调制到回路上，从而将总功率预算降低至2.7mA。

Here is shown a basic application diagram for a loop powered transmitter using the ADuC7060 microcontroller, AD421 4-20mA transmitter chip and an ADP2105 voltage regulator.

For loop powered transmitters the key specification is power consumption, the entire transmitter must consume less than 4mA of current from the loop.

The AD421 produces a regulated 5V DC output, The ADP2105 down-converts this to 2.5V for the digital circuitry, allowing the digital circuitry to consume approx. twice the current

It would at a 5V supply.

The transmitter must be able to signal a fault condition by setting the loop current to a value below 3.2mA. This can be further complicated if the transmitter must also support the HART digital communications protocol, in which case a ± 0.5 mA FSK signal is modulated onto the loop current. In this case the transmitter must be able to

Non-Loop Powered Transmitter

- ◆ Power Consumption not critical

- High power sensors
- Higher accuracy with calibration
- Faster data operations

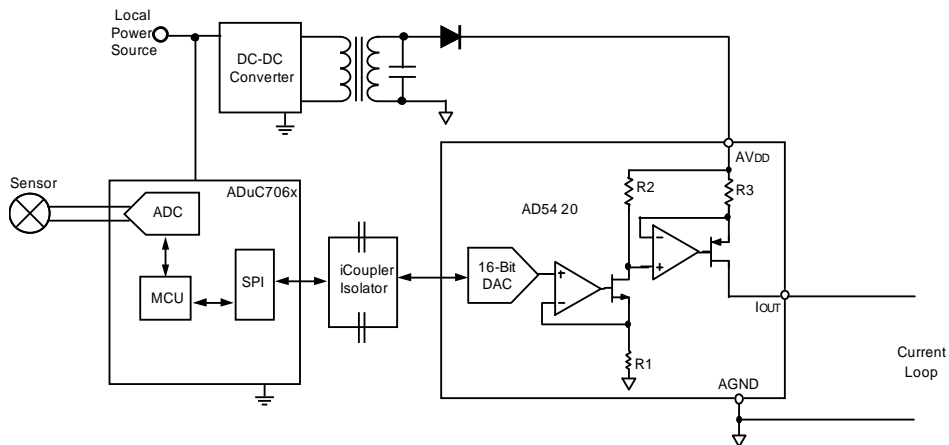

46



非回路供电的发送器的电源和电流回路采用分别的电缆。

因此整个发送器由本地电源供电，消除了功耗限制。

这些发送器一般用于功耗无法降低至4mA以下的应用。

比如需要高精度或者高采样率的应用中或者传感器元件需要很大电流的情况下。

Non-Loop powered transmitters have separate cabling for the power supply and the current loop,

So the entire transmitter is powered from a local supply removing the power consumption limitation,

These transmitters are typically used where the power consumption cannot be reduced below 4mA,

Such as in applications where high accuracy or high throughput is required or in cases where the sensor

Element requires a lot of current.

Amplifiers
Power Management
Processors
DSP
MCU
Converters

AD5420 - 16-Bit Current Source DAC

KEY FEATURES

- ◆ **16-Bit Resolution and Monotonicity**
- ◆ **I_{out} range**
 - 4mA-20mA, 0mA-20mA or 0mA-24mA
 - 0.1% Accuracy
 - 5ppm/C Output Drift
- ◆ **Functionality**
 - Reference (10 ppm/C)
 - Flexible Serial Digital Interface
 - Compliance to 60 V

Sampling

Now

Release

Q109

Generics

- ◆ AD5410 – 12Bit version

Packages

40-LFCSP
24-TSSOP

47

对于本地供电的发送器，AD5420是一个合适的回路驱动器，AD5420集成了16位DAC和电流回路驱动器电路，可以提供一个数字转4-20mA的回路解决方案。

And for locally powered transmitters the AD5420 is a suitable loop driver, it integrates a 16-bit dac and current loop driver circuitry, To provide a digital to 4-20mA loop solution.

Primarily Analog Communication Digital Communication is also possible

- ◆ Digital data can be modulated on top of the 4-20mA current using FSK (Frequency Shift Keying)
 - HART (Highway Addressable Remote Transducer)

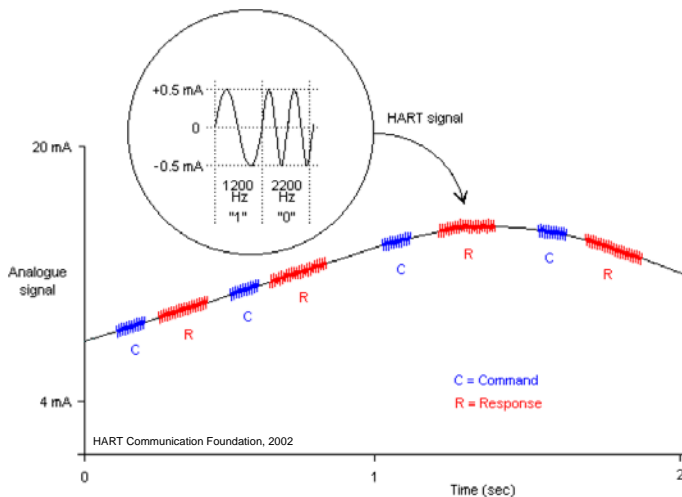

- ◆ Multivariable Transmitters
- ◆ Multidrop Networks
- ◆ Inventory Management
- ◆ Remote Calibration



在4至20mA回路上，只能发送一个参数，并且只能以一个方向发送。
HART数字通信使发送器能够发送多个参数（多变量发送器）。
它还可以支持多站网络，即多个发送器在一个公共回路上进行发送。
并且还可以由控制室控制发送器，实现远程校准和故障诊断。

HART采用频移键控（FSK）方案，其中1200 Hz表示1，2200 Hz表示0。
绝大多数新型发送器都具备HART能力。
需要使用HART调制解调器来实现数字通信。

On a 4-20mA loop only one parameter can be transmitted and only in one direction,
HART digital communication enables the transmitter to transmit multiple parameters
(multivariable transmitters)

It also allows multidrop networks where multiple transmitters can transmit on a common loop.

And also allows the transmitter to be controlled from the control room enabling Remote calibration and diagnostics.

HART uses a FSK scheme with 1200 Hz representing a 1 and 2200 Hz representing a 0.

The great majority of modern transmitters would include HART capability.

A HART modem is required to enable the digital communication

Adding HART communication capability

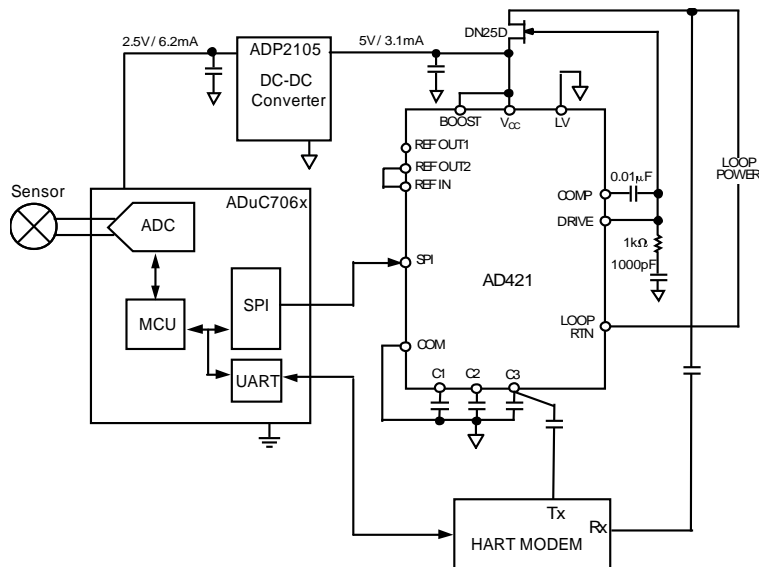

◆ See App Note
● AN-534

49



这个电路显示如何通过一个ADuC706x、一个AD421和一个HART调制解调器来实现HART功能。

对于发送，HART调制解调器接受来自控制器的比特流，并将其转换成FSK信号，然后FSK信号被施加到AD421，AD421再将FSK信号调制到回路上。

对于接收，HART调制解调器从回路提取FSK信号，并将其转换成比特流，然后发送到控制器，从而实现发送器与控制室之间的半双工通信。

更多的细节可从应用笔记AN-534中获取。

This circuit shows how HART capability can be achieved with an ADuC706x ,an AD421 and a HART modem.

For transmission The HART modem accepts a bit stream from the controller and converts it into an FSK signal which is

Then applied to the AD421, the AD421 modulates the FSK signal onto the loop.

For reception the modem takes the FSK signal from the loop, converts it into a bit stream

Which it sends to the controller, implementing half duplex communication between the transmitter and the control room.

Further details are available in Application Note AN-534.



PLC Reference Design



下面是本次研讨会的最后一个部分，在这个部分我们将介绍PLC输入和输出模块的参考设计。这里列举的信号链中的所有ADI器件都已经过充分的验证。

This is the final section of this session where I will introduce our PLC input and output module reference design,
All ADI components are used in the signal chain and it has been fully built and verified.

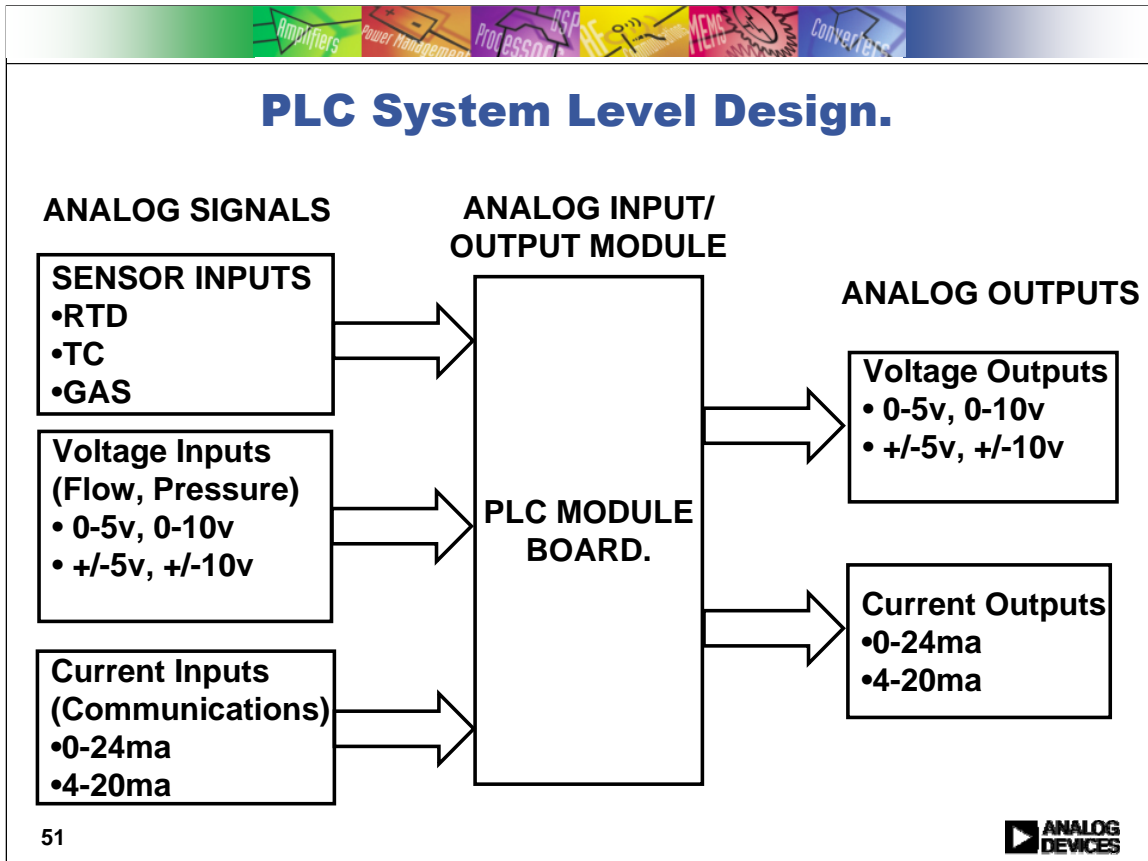

整个设计由4个输入通道和4个输出通道组成，输入通道能够接受范围很大的输入电平：幻灯片所示的有来自RTD和TC的低电平电压输入信号，高达 $\pm 10V$ 的电压信号，以及4到20mA的电流信号。

输出通道能够输出 $\pm 5V$ 至 $\pm 10V$ 范围内的电压信号以及4到20mA的电流信号。

The full design consists of 4 input channels and 4 output channels, the input channels are capable of accepting a wide range of input levels;

low level inputs from RTD and TC, up to $\pm 10V$ and also 4-20mA current signals as shown.

The output channels are capable of outputting voltage signals in the range of $\pm 5V$ up to $\pm 10V$ and 4-20mA signals.

PLC REFERENCE DESIGN SPECIFICATIONS

- ◆ **Analog Input Section Requirements:**
 - 4 Independent isolated input channels.
 - Each channel needs to be capable of accepting the following inputs:
 - ◆ 0-20 ma, 4-20ma, 0-5V, 0-10V, +/-5V, +/-10V, RTD, TC.
- ◆ **Analog Output Section Requirements:**
 - 4 Independent Isolated Output Channels
 - Each channel needs to be capable of outputting the following signals:
 - ◆ 0-20 ma, 4-20ma, 0-5V, 0-10V, +/-5V, +/-10V.
- ◆ **Total System Accuracy Requirements:**
 - 0.05% accuracy for total System.
 - Gain/Offset Calibration required – i.e. total accuracy needs to include gain and offsets of analog components.

52



如上所述，可以在设计上配置出各种不同的输入和输出信号范围。电压模式下的系统精度为0.05%，电流模式下的系统精度为0.1%

应在ADC上进行增益校准，但DAC不需要，这是因为这些范围在工厂已经进行了测试和编程，在整个温度范围内可确保正常工作。

As mentioned, a wide variety of input and output signal ranges can be configured on the design. The System accuracy in voltage mode is 0.05% and in current mode is 0.1%.

Gain calibration should be performed on the ADC but is not needed for the DAC as these ranges are tested and programmed in the factory and guaranteed across temperature.

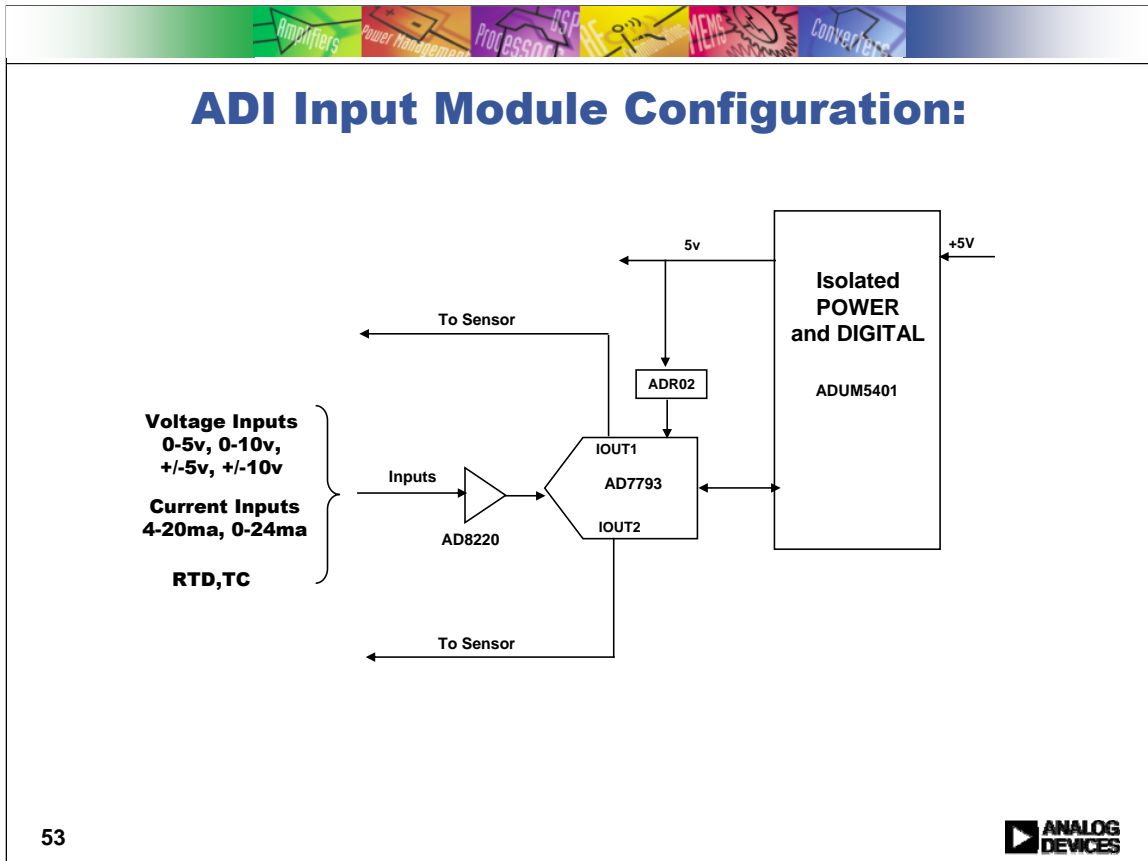

这是输入模块部分的框图。ADC采用AD7793。采样速率对于工业设计而言一般并不重要，因此 Σ - Δ ADC是理想选择，这是因为其噪声低。AD8220仪表放大器用来进一步改善输入信号并实现高CMRR。基准采用ADR02。对于单电源通道，ADUM5401用来提供电源和数字隔离。

This is the block level of the input module section. The AD7793 is used for the ADC. Update rate is generally not critical for Industrial designs therefore

A Sigma Delta ADC is ideal due to its low noise. High frequency noise is digitally removed using noise quantization on the chip. An AD8220 instrumentation amplifier is used to

further improve input signal and achieve high CMRR. An ADR02 is used for Reference. For single supply channels an ADUM5401 is used to supply both power and digital isolation.

AO - OUTPUT MODULE CONFIGURATION

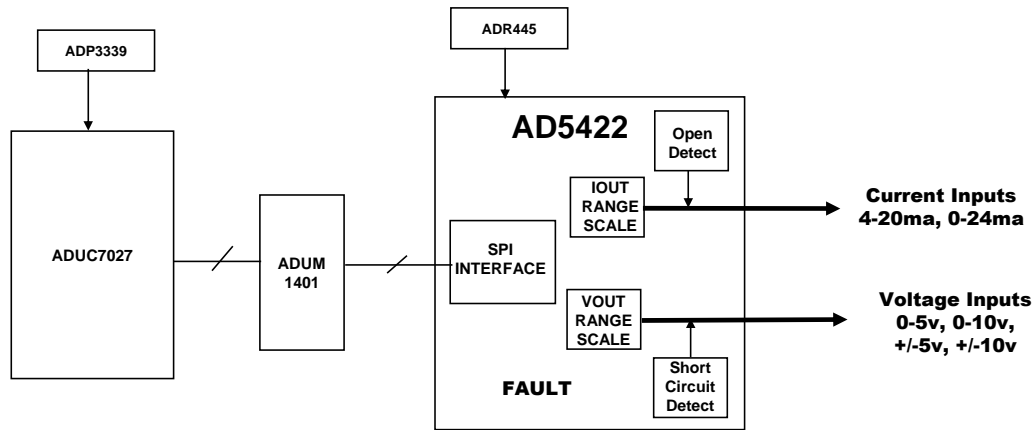

54



输出端则采用AD5422。这个集成解决方案可在输出端提供可编程的电流和电压，以及开路 and 短路检测。ADR445电压基准可用于注重温漂的高性能系统。否则可以直接采用内部基准。

On the output side the AD5422 is used. The integrated solution provides programmable current and voltage on the output, as well

as open and short circuit detection. The ADR445 voltage reference can be used in high performance systems where temperature drift is critical. Otherwise the internal reference can be used.

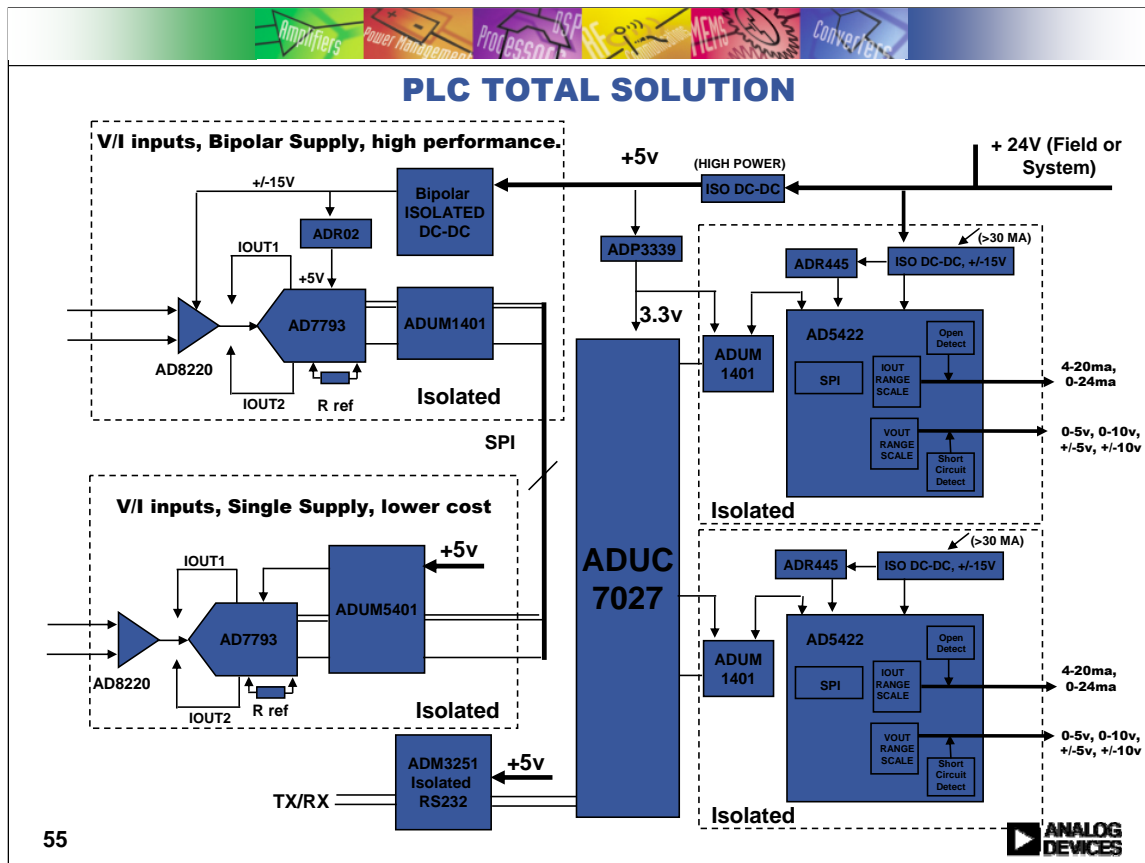

这是整个PLC模拟模块参考设计的结构框图。它包含单5V电源输入通道以及+/-15V双电源输入通道。所有的输出通道都由+/-15V电源供电。ADuC7027用来负责处理，它可以存储用于ADC校准的所有代码以及用来与DAC和ADC进行通信的驱动。

电路板由24V的DC电压供电，然后该电源被转换成一个隔离的5V电源和一个隔离的+/-15V电源，+/-15V电源向输出通道供电。5V电源向电路板的数字部分供电，同时也被转换成+/-15V电源用于两个双极性输入通道。5V电源通过ADuM5401隔离，然后为两个单极性输入通道供电。所有通道之间都完全隔离。电路板通过RS232接口与计算机进行通信，这也是采用RS232隔离器ADM3251进行隔离的。

This is a Block Diagram for the total PLC analog module reference design. It contains single 5V supply input channels as well as bipolar +/-15v supply input channels. All output channels are supplied from +/-15v. An ADuC7027 is used for Processing which can store all the cal codes for the ADC calibration routine and the drivers for communicating with the DACs and ADCs.

The board accepts a DC voltage power supply of 24V, this is then converted to an isolated 5V supply and to an isolated +/-15V supply, the +/-15V supplies the output channels. The 5V supply powers the digital section of the board as well as being converted to +/-15V for the two bipolar input channels, The 5V supply is isolated with an ADuM5401 before being applied to the two unipolar input channels. All channels are fully isolated from each other. The board communicates with a computer over a RS232 link, this is also isolated using an ADM3261 RS232 isolator.

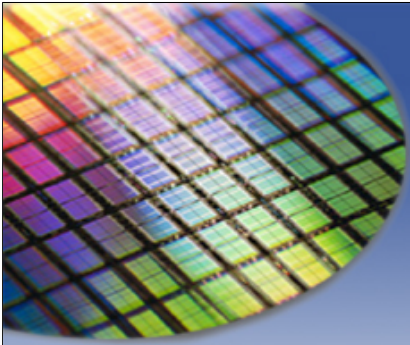

Thank You!

China Applications Support Team, Analog Devices, Inc
Toll-free Number: 800-810-1742 (China Mainland Only)
Toll-free Fax: 800-810-1747 (China Mainland Only)
E-mail: china.support@analog.com



analog is everywhere.™



感谢您参加本次研讨会。如有问题，请联系ADI免费技术支持热线800-810-1742或发email至china.support@analog.com